

Packing Sizes & Weight

Model	Dim.(mm)(LxWxH)
BWE2-6	520×260×590
BWE4-4	
BWE8-2	
BWE8-3	
BWE8-4	
BWE8-5	660×290×700
BWE12-2	
BWE12-3	
BWE16-2	
BWE20-1	
BWE20-2	520×260×590
BWJE2-6	
BWJE4-4	
BWJE4-5	
BWJE4-6	
BWJE8-2	580×260×570
BWJE8-3	
BWJE8-4	
BWJE8-5	
BWJE12-2	
BWJE12-3	660×290×700
BWJE16-2	
BWJE20-1	
BWJE20-2	
BL(T)E2-6	
BL(T)E2-7	800×330×670
BL(T)E2-9	
BL(T)E2-11	
BL(T)E2-13	800×330×740
BL(T)E2-15	
BL(T)E4-4	
BL(T)E4-5	800×330×670
BL(T)E4-6	
BL(T)E4-7	
BL(T)E4-8	800×330×740
BL(T)E4-10	
BL(T)E4-12	
BL(T)E8-2	800×330×870
BL(T)E8-3	
BL(T)E8-4	
BL(T)E8-5	900×360×720
BL(T)E8-6	
BL(T)E12-2	
BL(T)E12-3	900×360×870
BL(T)E16-2	
BL(T)E20-2	
BL(T)E20-2	

2BW(J)E/2BL(T)E

Full intelligent backpack frequency conversion pump

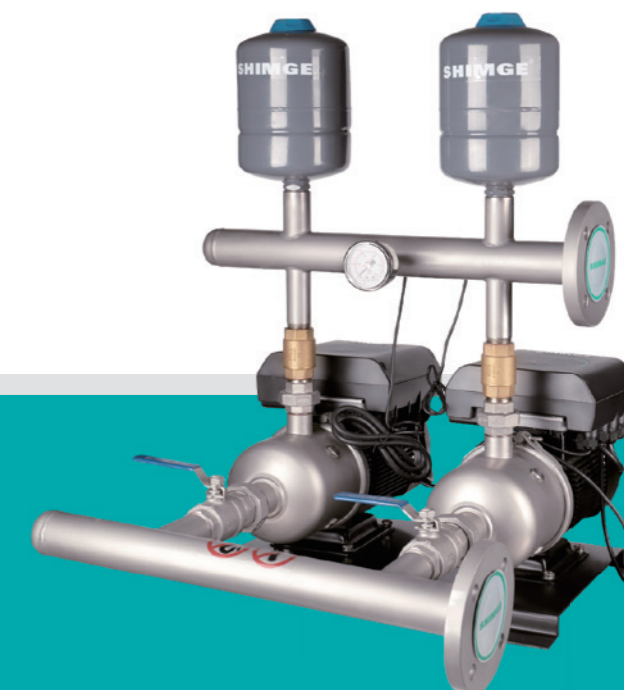

Field of Application

- **Residential water:** supercharger on top of high-rise buildings, apartments, villas, etc
 - **Public places:** schools, restaurants, stations, hospitals, gymnasiums, etc
 - **Commercial buildings:** hotels, office buildings, department stores, etc
 - **Irrigation:** farms, orchards, parks, etc
 - **Industry:** manufacturing, food industry, factories and other constant pressure water supply places
- Water chillers are used together



Product Features

Inverter :IP65 protection grade, safe and reliable.
High integration: integration of water pump and frequency converter, small size, easy installation, save space.
Automatic control: according to the user's pipe network pressure, the running state can be adjusted automatically to achieve the best running state, so that the system is more energy saving. When no one uses water, it can automatically maintain pressure and hibernate, which has obvious energy-saving effect. When the water pump is faulty, it will automatically track and judge and deal with it in real time.
It is easy to operate and simple: it can directly achieve man-machine interaction function by pressing buttons and displaying on the frequency converter. Users can set pressure related Settings according to their actual running status and obtain relevant information. When there is an anomaly, the abnormal information can be obtained.
Constant power operation: When the controller reaches the limit power, it will be adjusted according to the actual operation condition. In the case of ensuring the user's water consumption as far as possible, the output power will remain unchanged to realize the protection of the motor.

Equipment spectrum

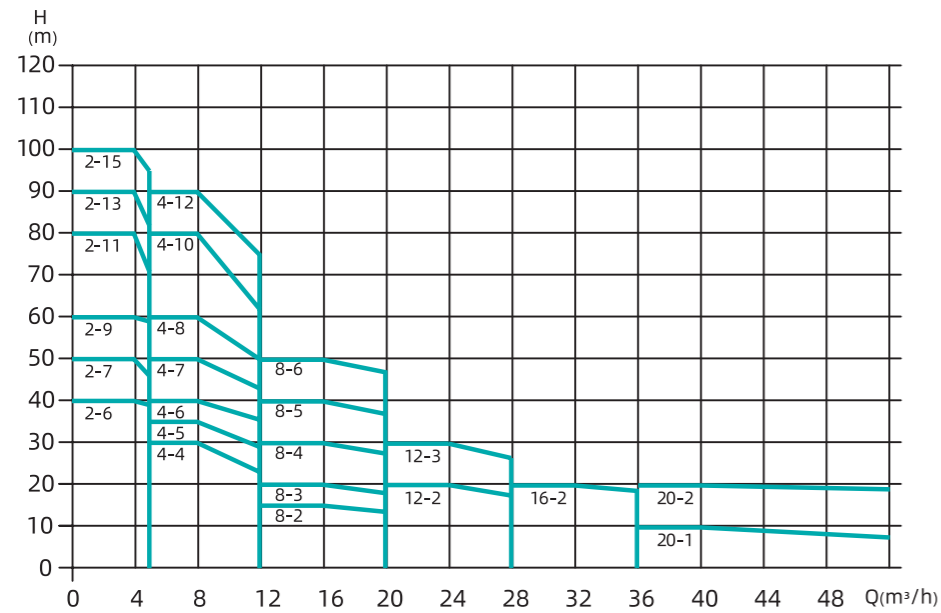

Working conditions

- 1.Input voltage: single phase 220V/Δ、 three phase 380V/Y ,50Hz/60Hz;
- 2.The altitude of the installation site shall not exceed 1000m;
- 3.The temperature of the operating environment: -5°C -40°C ;
- 4.There is no explosive medium in the surrounding air, and the medium doesn't contain gases that can corrode the metal and damage insulation or conductive dust. Use in the environment of Pollution Level 2;
- 5.Environment humidity: 10-90% RH (non-condensing); 6. display mode: LED display;
- 7.adjustment mode: press the button to select the mode and the pressure setting;
- 8.power factor: more than 0.95;
- 9.safety requirements: to meet the CE certification standards;
10. waterproof grade: Ip65.

Function description

Number	Function description	Fuction	Remark
1	Constant pressure	By adjusting the speed to meet the constant pressure, to achieve customer waterstate of real time Variation.	-
2	Dormancy	When the user cdloses the valve, in the state of useless water, the judge and enter the sleep state, to sleep, when the valve again,when the door is opened, the controller drives the pump to run.	-
3	Water shortage protection	Enter the water shortage protection when the system is dry, and suspend the operation of the pump. After the set time, restart the operation. If the water shortage protection is started three times in a row, the system will automatically shut down and cannot run.	There is a certain deviation" in the minimum power of w ater' pump operation due to different use environments. It is suggested to record the pump power during dry rotation first, and modify the "P8" parameter. to record power +50W.
4	Fault protection	When an abnormal state and fault occurs, to protect the state,And it is only through the power failure that can eliminate the fault information.	-
5	Limited power	Flow is too large, can not guarantee the export pressure,imited to. maximum power operation. Ensure that thepump will not burn the machine due to overload. Can work properly.	-
6	High power factor	Power factor > 0.95, to achieve the system energy efficiency.	-
7	Multiple- operation for pressure supply	The first one starts to run to full frequency, and determines whether the performance is consistent. If t is not, the other one will be loaded. After loading, the final running frequencies of the two sets are consistent.	-
8	Intelligent shutdown	After the parall operation frequency is lower than 35, one will be automaticall shut down to save electricity.	-
9	automatic switchover	Automatically switch another water pump to work in the set time of continuous operation (2 hours). When multiple units work online, they are automatically switched according to the number of online units to achieve uniform operation.	When the number of parallel connection exceedds 2, the set working time is. the sum of running time and sleep time.
10	Error rejection	If there is a pump failure when multiple pumps are running online, the failure machine can be automatically eliminated and continue to run.	-
11	Automatic correction	In case of communication failure of the host, another host is automatically. negotiated to continue networking operation. The faulty machine should report the fault code.	-

Note: the target pressure can only be set on the master machine, and the slave machine cannot set the pressure.

Performance Parameters

Number	Model	Input voltage	Setting range of constant pressure value kg/cm ²	Factory-set constant pressure value (rated pressure) kg/cm ²	Inlet diameter	Outlet diameter	Single-pump power kW	Maximum lift (zero flow) m	Rated flow m ³ /h	Volume of pressure tank(L)
1	2BWE2-6	220V/380V	0.5-4	4	DN50	DN50	0.75	40	2	3*2
2	2BWE4-4	220V/380V	0.5-3	3	DN50	DN50	0.75	30	4	3*2
3	2BWE8-2	220V/380V	0.5-1.5	1.5	DN80	DN80	0.75	15	8	5*2
4	2BWE8-3	220V/380V	0.5-2	2	DN80	DN80	1.1	20	8	5*2
5	2BWE8-4	220V/380V	0.5-3	3	DN80	DN80	1.5	30	8	5*2
6	2BWE8-5	220V/380V	0.5-4	4	DN80	DN80	2.2	40	8	5*2
7	2BWE12-2	220V/380V	0.5-2	2	DN80	DN80	1.2	20	12	5*2
8	2BWE12-3	220V/380V	0.5-3	3	DN80	DN80	1.8	30	12	5*2
9	2BWE16-2	220V/380V	0.5-2	2	DN80	DN80	2.2	20	16	5*2
10	2BWE20-2	220V/380V	0.5-2	2	DN80	DN80	2.2	20	20	5*2
11	2BWJE2-6	220V/380V	0.5-4	4	DN50	DN50	0.75	40	2	3*2
12	2BWJE4-4	220V/380V	0.5-3	3	DN50	DN50	0.75	30	4	3*2
13	2BWJE4-5	220V/380V	0.5-3.5	3.5	DN50	DN50	1.1	35	4	3*2
14	2BWJE4-6	220V/380V	0.5-4.5	4.5	DN50	DN50	1.1	45	4	3*2
15	2BWJE8-2	220V/380V	0.5-1.5	1.5	DN80	DN80	0.75	15	8	5*2
16	2BWJE8-3	220V/380V	0.5-2	2	DN80	DN80	1.1	20	8	5*2
17	2BWJE8-4	220V/380V	0.5-3	3	DN80	DN80	1.5	30	8	5*2
18	2BWJE8-5	220V/380V	0.5-4	4	DN80	DN80	2.2	40	8	5*2
19	2BWJE12-2	220V/380V	0.5-2	2	DN80	DN80	1.2	20	12	5*2
20	2BWJE12-3	220V/380V	0.5-3	3	DN80	DN80	1.8	30	12	5*2
21	2BWJE16-2	220V/380V	0.5-2	2	DN80	DN80	2.2	20	16	5*2
22	2BWJE20-2	220V/380V	0.5-2	2	DN80	DN80	2.2	20	20	5*2
23	2BL(T)E2-6	220V/380V	0.5-4	4	DN50	DN50	0.75	40	2	3*2
24	2BL(T)E2-7	220V/380V	0.5-5	5	DN50	DN50	0.75	50	2	3*2
25	2BL(T)E2-9	220V/380V	0.5-6	6	DN50	DN50	1.1	60	2	5*2
26	2BL(T)E2-11	220V/380V	0.5-8	8	DN50	DN50	1.1	80	2	5*2
27	2BL(T)E2-13	220V/380V	0.5-9	9	DN50	DN50	1.5	90	2	5*2
28	2BL(T)E2-15	220V/380V	0.5-10	10	DN50	DN50	1.5	100	2	5*2
29	2BL(T)E2-18	220V/380V	0.5-13	13	DN50	DN50	2.2	130	2	5*2
30	2BL(T)E2-22	220V/380V	0.5-16	16	DN50	DN50	2.2	160	2	5*2
31	2BL(T)E4-4	220V/380V	0.5-3	3	DN50	DN50	0.75	30	4	3*2
32	2BL(T)E4-5	220V/380V	0.5-3.5	3.5	DN50	DN50	1.1	35	4	3*2
33	2BL(T)E4-6	220V/380V	0.5-4	4	DN50	DN50	1.1	40	4	3*2
34	2BL(T)E4-7	220V/380V	0.5-5	5	DN50	DN50	1.5	50	4	3*2
35	2BL(T)E4-8	220V/380V	0.5-6	6	DN50	DN50	1.5	60	4	5*2
36	2BL(T)E4-10	220V/380V	0.5-8	8	DN50	DN50	2.2	80	4	5*2
37	2BL(T)E4-12	220V/380V	0.5-9	9	DN50	DN50	2.2	90	4	5*2
38	2BL(T)E8-2	220V/380V	0.5-1.5	1.5	DN80	DN80	0.75	15	8	5*2
39	2BL(T)E8-3	220V/380V	0.5-2	2	DN80	DN80	1.1	20	8	5*2
40	2BL(T)E8-4	220V/380V	0.5-3	3	DN80	DN80	1.5	30	8	5*2
41	2BL(T)E8-5	220V/380V	0.5-4	4	DN80	DN80	2.2	40	8	5*2
42	2BL(T)E8-6	220V/380V	0.5-5	5	DN80	DN80	2.2	50	8	5*2
43	2BL(T)E12-2	220V/380V	0.5-2	2	DN80	DN80	1.5	20	12	5*2
44	2BL(T)E12-3	220V/380V	0.5-3	3	DN80	DN80	2.2	30	12	5*2
45	2BL(T)E16-2	220V/380V	0.5-2	2	DN80	DN80	2.2	20	16	5*2
46	2BL(T)E20-2	220V/380V	0.5-2	2	DN80	DN80	2.2	20	20	5*2

Overall Dimensions of Variable-frequency Pump

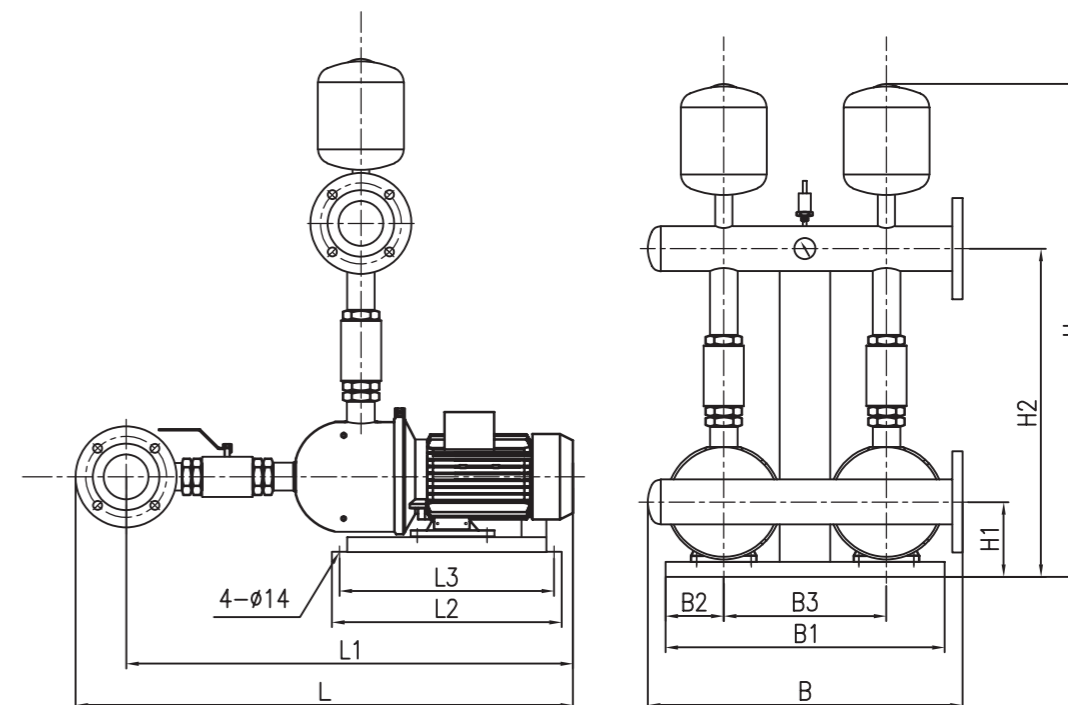

Model	L (mm)	L1 (mm)	L2 (mm)	L3 (mm)	B (mm)	B1 (mm)	B2 (mm)	B3 (mm)	H (mm)	H1 (mm)	H2 (mm)
2BWE2-6	746.5	552	400	360	580	500	290	105	806	145	476
2BWE4-4	757.5	563	400	360	580	500	290	105	810	145	480
2BWE8-2	920	708	480	400	670	550	320	115	938	152	568
2BWE8-3	920	708	480	400	670	550	320	115	938	152	568
2BWE8-4	958	746	480	400	670	550	320	115	938	152	568
2BWE8-5	958	746	480	400	670	550	320	115	938	152	568
2BWE12-2	920	708	480	400	670	550	320	115	938	152	568
2BWE12-3	958	746	480	400	670	550	320	115	938	152	568
2BWE16-2	958	746	480	400	670	550	320	115	938	152	568
2BWE20-2	958	746	480	400	670	550	320	115	938	152	568
2BWJE2-6	762.5	568	400	360	580	500	290	105	773.5	145	443.5
2BWJE4-4	774.5	580	400	360	580	500	290	105	777.5	145	447.5
2BWJE4-5	802.5	608	400	360	580	500	290	105	777.5	145	447.5
2BWJE4-6	830.5	636	400	360	580	500	290	105	777.5	145	447.5
2BWJE8-2	769	557	480	440	670	550	320	115	874	152	504
2BWJE8-3	801	589	480	440	670	550	320	115	874	152	504
2BWJE8-4	856	644	480	440	670	550	320	115	874	152	504
2BWJE8-5	888	676	480	440	670	550	320	115	874	152	504
2BWJE12-2	768.5	556.5	480	440	670	550	320	115	874	152	504
2BWJE12-3	823.5	611.5	480	440	670	550	320	115	874	152	504
2BWJE16-2	804.5	592.5	480	440	670	550	320	115	874	152	504
2BWJE20-2	842.5	630.5	480	440	670	550	320	115	895	152	525

Overall Dimensions of Variable-frequency Pump

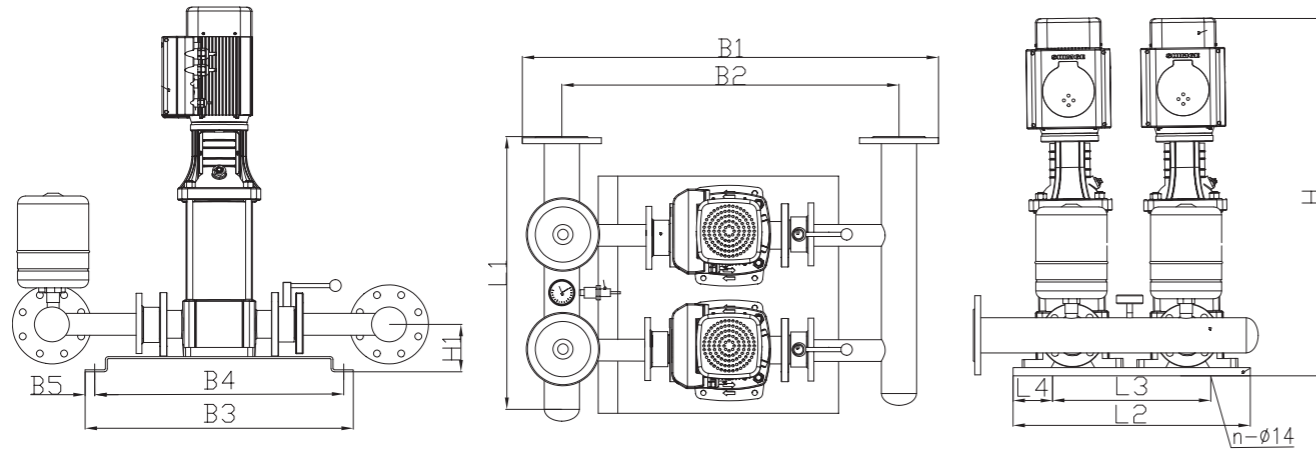

Model	L1 (mm)	L2 (mm)	L3 (mm)	L4 (mm)	B1 (mm)	B2 (mm)	B3 (mm)	B4 (mm)	B5 (mm)	H (mm)	H1 (mm)
2BL(T)E2-6	550	510	310	100	790	625	430	390	20	629	109
2BL(T)E2-7	550	510	310	100	790	625	430	390	20	647	109
2BL(T)E2-9	550	510	310	100	790	625	430	390	20	683	109
2BL(T)E2-11	550	510	310	100	790	625	430	390	20	719	109
2BL(T)E2-13	550	510	310	100	790	625	430	390	20	813	109
2BL(T)E2-15	550	510	310	100	790	625	430	390	20	849	109
2BL(T)E2-18	550	510	310	100	790	625	430	390	20	903	109
2BL(T)E2-22	550	510	310	100	790	625	430	390	20	975	109
2BL(T)E4-4	550	510	310	100	809	644	430	390	20	629	109
2BL(T)E4-5	550	510	310	100	809	644	430	390	20	656	109
2BL(T)E4-6	550	510	310	100	809	644	430	390	20	683	109
2BL(T)E4-7	550	510	310	100	809	644	430	390	20	768	109
2BL(T)E4-8	550	510	310	100	809	644	430	390	20	795	109
2BL(T)E4-10	550	510	310	100	809	644	430	390	20	849	109
2BL(T)E4-12	550	510	310	100	809	644	430	390	20	903	109
2BL(T)E8-2	700	715	515	100	877	677	560	520	20	657	114
2BL(T)E8-3	700	715	515	100	877	677	560	520	20	689	114
2BL(T)E8-4	700	715	515	100	877	677	560	520	20	771	114
2BL(T)E8-5	700	715	515	100	877	677	560	520	20	803	114
2BL(T)E8-6	700	715	515	100	877	677	560	520	20	835	114
2BL(T)E12-2	700	715	515	100	905	705	560	520	20	717	124
2BL(T)E12-3	700	715	515	100	905	705	560	520	20	749	124
2BL(T)E16-2	700	715	515	100	905	705	560	520	20	744	124
2BL(T)E20-2	700	715	515	100	905	705	560	520	20	744	124

WWG

Non-negative pressure water supply equipment

The 2nd generation

Type A

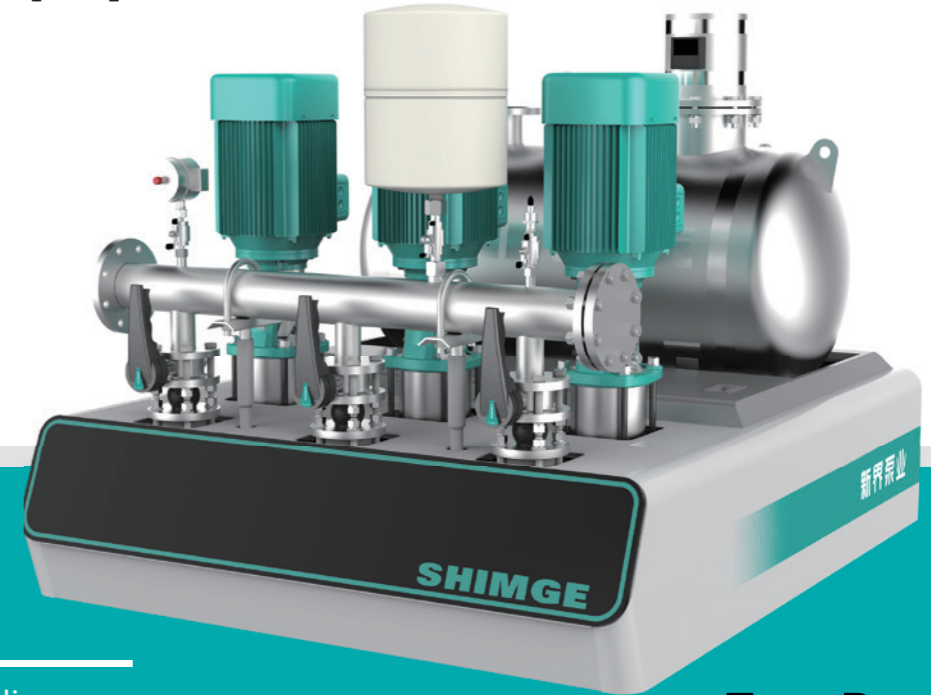

Type B

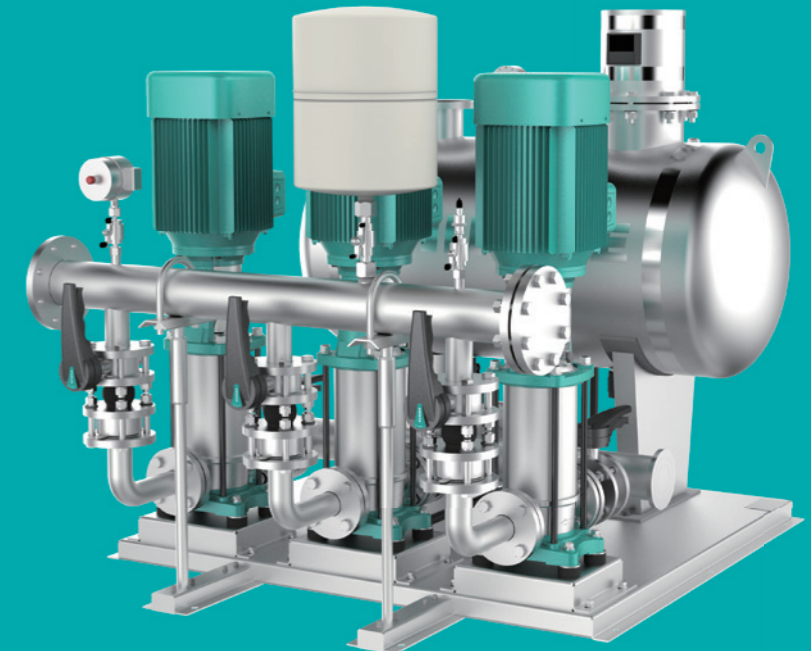

Applicable Scope

Domestic Water: high-rise buildings, residential communities, villas

Public Areas: schools, hospitals, gymnasiums, golf courses airports

Commercial Buildings: hotels, office buildings, department stores, large saunas

Irrigations: parks, amusement parks, orchards, farms, etc.

Manufacturings: production and manufacturing, washing equipment, food factories, industrial and mining enterprises

Others: renovation of pools and other forms of water supply