

SHIMGE[®]
..... ——— for better life



Manual of AL(T) Stainless Steel Pump



Scan the QR code above to know more information about shimge and its products:
<https://www.shimgepump.com/>

SHIMGE PUMP INDUSTRY (ZHEJIANG) CO., LTD.

Add: Dayangcheng Industrial Zone, Daxi Town, Wenling, Zhejiang Province, China

Tel: +86-576-86339960

Fax: +86-576-86337079

Email: admin@shimge.com

SHIMGE PUMP INDUSTRY (ZHEJIANG) CO., LTD.

AL(T) Stainless Steel Multi-stage Centrifugal Pump



Equipped with GB18613 high efficiency standard motor, and provided with Japan NSK bearing and cold-rolled 50W800 silicon steel sheet, the pump has such good features as high efficiency, low noise, and no maintenance; With the fully enclosed structure, the protection class of P55, the insulation class of F, and the unique “double-locked” drive-end bearing, the pump can bear higher inlet pressure.



In the balanced-type cartridge shaft seal, all the parts are assembled together without axial movement; it causes no wear to the shaft and rubber parts. It has such features as quick replacement, easy installation, and safe operation. The dynamic seal is made of hard alloy material, and the static seal is made of fluororubber materials, which makes the mechanical seal have such significant advantages as high temperature resistance, long life, and convenient replacement.



The most internationally advanced precision laser all-welding technique is adopted to avoid spot welding and ensure the high strength and high efficiency of the impeller. Processing technology: Adopt modern and advanced processing techniques and processing equipment such as precision casting, CNC lathe, machining center, and laser welding.



Floating seal ring is adopted in the cavity to minimize the internal leakage due to pressure difference inside the pump, and prevent the energy that shall be applied to the liquid which leaks back to the pump cavity from being consumed.



The pump core assembly adopts the interlocking of the multi-stage impeller, back locking of the clamp nut, and interlocking of the component system to minimize the clearance between the stages of the impeller, improve the hydraulic efficiency of the impeller, and ensure the stability, reliability and high efficiency of the pump core assembly.



1 Product Overview

AL/ALT series product is a kind of new-generation high-efficiency non-self-priming vertical multi-stage centrifugal pump newly self-developed by reference to European standards. By adopting brand-new industrial design, the energy efficiency index MEI of the product reaches 0.7 and above; the product adopts a good hydraulic model and advanced manufacturing process, flow passage components of the pump body are formed by stamping and welding of high-quality 304 stainless steel, and the shaft seal adopts hard alloy and fluororubber mechanical seal. The product can deliver a variety of media from tap water to industrial liquid, and is applicable to different ranges of temperature, flow, and pressure; the whole machine is compact in structure, low in noise, and small in volume, with significant energy-saving effects.

2 Model Definition

AL (T) 5 - 7 - F - S - W - S - R

- R: Hot water type (not indicated for normal temperature type)
- S: Three-phase; D: Single-phase
- W: Frequency 50Hz, L: Frequency 60Hz
- S: 304, L: 316, P: Ordinary type
- F: Lap-joint flange; L: Thread, F1: Threaded flange
- Number of stages
- Rated flow (m³/h)
- Some flow passage components are cast iron parts; and they are not indicated when all flow passage components are made of stainless steel
- Light stainless steel vertical multi-stage centrifugal pump

3 Application Fields

- **Pressurized water supply** | Water delivery for filtration in water plants, pressurization of main pipe networks, water supply for high-rise buildings, and fire water supply
- **Water treatment system** | Ultrafiltration system, reverse osmosis system, distillation system, separator, and swimming pool water treatment system
- **Industrial pressurization** | High-pressure washing system, cleaning system, and process water system
- **Delivery of industrial liquids** | Cooling and air conditioning system, boiler water supply and condensing system, and lathe supporting system
- **Irrigation** | Farmland irrigation, spray irrigation, and trickle irrigation

4 Service Conditions

- Thin and clean liquid not containing solid particles of fiber
- The product can be applied to deliver the slightly corrosive medium
- Medium temperature: Normal temperature type: 0° C~+68° C, hot water type: 0° C~+120° C
- Ambient temperature: -15° C~+40° C
- Maximum ambient pressure: 1.0MPa
- When the density or viscosity of the delivered medium is greater than that of water, it shall be considered to equip a motor with greater power.

5 Selection of Motor

Fully-enclosed IE3 air-cooled standard motor Japanese NSK bearing, 50W800 cold-rolled silicon steel sheet

- Protection class: IP55
- Insulation class: Class F
- Working mode: S1
- Voltage level: 220V/50Hz, 380V/50Hz

Performance Range

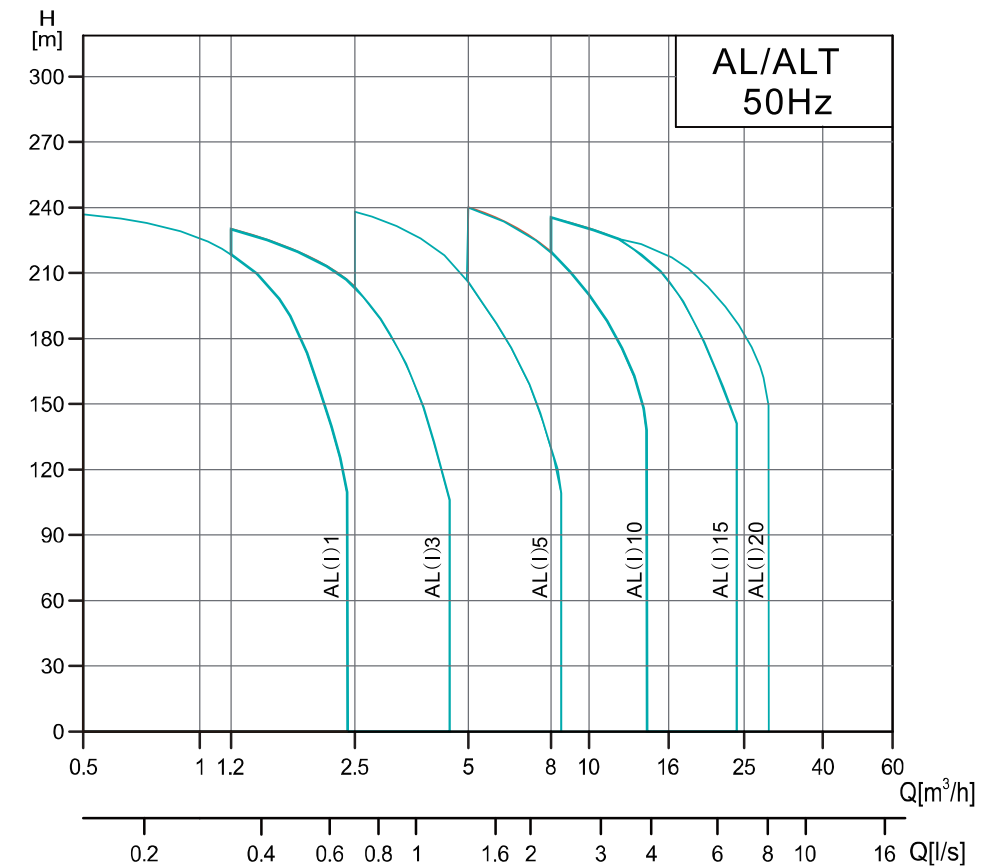

Model	Rated flow (m ³ /h)	Flow range (m ³ /h)	Maximum pressure (bar)	Motor power (kW)	Maximum efficiency (%)	Temperature range (°C)	Flange pressure	Flange	Pipe thread
AL(T)1	1	0.5~2.4	2.4	0.37~2.2	48	Normal temperature type: 0°C~68°C Hot water type: 0°C~120°C	PN25	DN25	R ₂ 1¼
AL(T)3	3	1.2~4.4	2.3	0.37~3	58		PN25	DN25	R ₂ 1¼
AL(T)5	5	2.5~8.5	2.4	0.37~5.5	70		PN32	DN25	R ₂ 1¼
AL(T)10	10	5~14	2.4	0.75~11	72		PN40	DN25	R _c 2
AL(T)15	15	8~24	2.4	1.1~15	73		PN50	DN25	R _c 2
AL(T)20	20	10~29	2.3	1.1~18.5	73		PN50	DN25	R _c 2

Minimum Inlet Pressure - NPSH

Calculation of minimum inlet pressure

If the pressure in the pump is lower than the vapor pressure of the delivered medium, cavitation may occur, affecting the performance of the pump; to avoid the occurrence of such situation, a minimum pressure shall be ensured at the inlet side of the pump, and the maximum suction head H (m) can be calculated according to the formula below:

$$H = P_b \times 10.2 - NPSH - H_f - H_v - H_s$$

P_b: Atmospheric pressure, in bar (in a closed pipeline, it can be regarded as the system pressure bar of the closed system);

NPSH: Net positive suction head, in m (the value read at the maximum flow on the Q-NPSH curve);

H_f: Line loss at the suction tube (the value corresponding to the maximum flow that may occur in the pipeline);

H_v: Vapor pressure of medium, in m (the evaporation number of medium at corresponding temperature; usually, the medium is clean water by default, as shown in Figure 4 on the right);

H_s: Safety margin, in m, which usually takes 0.5.

Calculation result: If H is a positive value, the pump is installed in the suction mode, otherwise, the pump is installed in the back flow mode.

Note: Usually, the calculation may not be conducted, and H is calculated only when it comes to using a combination of pumps under the following circumstances

- The medium temperature is high
- The flow velocity of liquid exceeds the rated value
- The suction head is large, or the inlet pipeline is long
- The system pressure is too small
- The inlet condition is poor

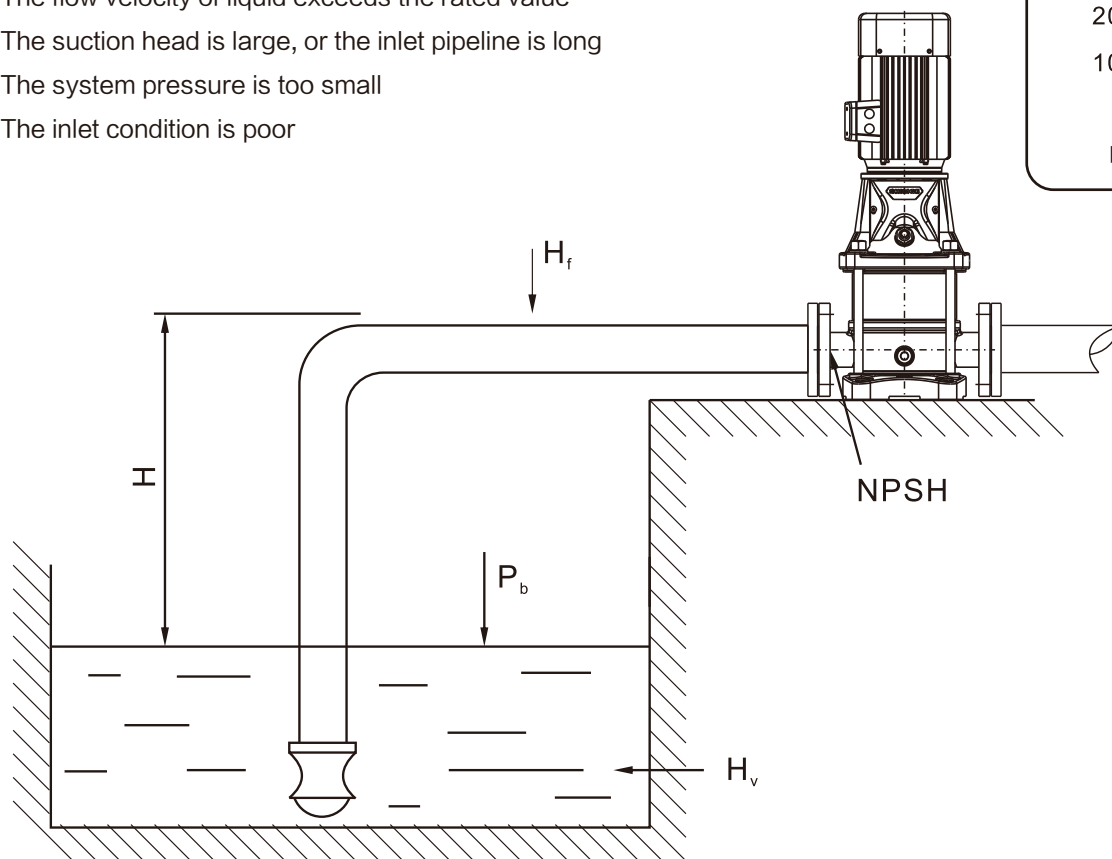
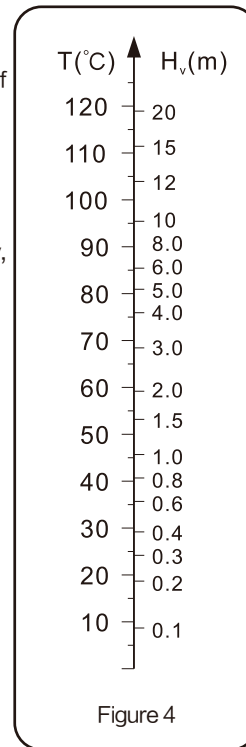

Maximum Working Pressure

The figure below indicates the limits of pressure and temperature, and the pressure and temperature shall be within the indicated range.

Model	Curve number
AL(T)1,3,5	1
AL(T)10,15,20	2

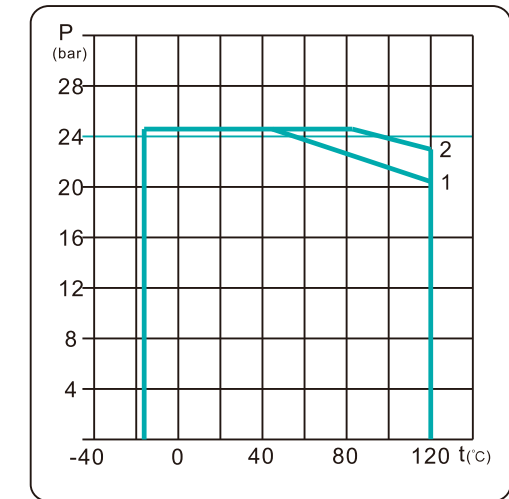

Maximum Ambient Temperature

When the pump is running at the ambient temperature above 40° C or at the altitude above 1,000m, the output power P2 of the motor decreases due to low air density and poor cooling effect. When the pump is running in the above case, the motor power shall be selected properly.

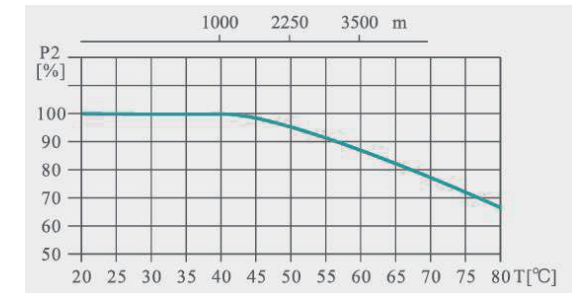

Maximum Ambient Temperature

Serial No.	Configuration	Configuration description	Applicable working conditions	Configuration situation
1	EUBV	Cartridge type E, hard alloy dynamic ring U, resin impregnated graphite static ring B, fluororubber V	1. Normal working condition of cold water at 0° C~68° C, containing no particle, with oil allowed. 2. Normal working condition of hot water at 68° C~90° C, containing no particle, with oil allowed	Conventional
2	EQQE	Cartridge type E, silicon carbide dynamic ring Q, silicon carbide static ring Q, EPDM E	1. Working condition of hot water at 90° C~120° C, containing a small number of particles but no oil.	Conventional
3	EQQV	Cartridge type E, silicon carbide dynamic ring Q, silicon carbide static ring Q, fluororubber V	1. Acid medium PH=5~7. 2. Alkaline medium PH=5~7. 3. Working condition of hot water at 68° C~90° C, containing a small number of particles and oil. 4. Oil products.	Customized
4	EUUE	Cartridge type E, hard alloy dynamic ring U, resin impregnated graphite static ring B, EPDM E	1. Frozen water below 0° C. 2. Alkaline medium with crystals. 3. Medium containing a lot of particles. 4. Working condition with the pressure higher than 2MPa.	Customized

Structural Diagram of AL(T)1, 3, 5

Structural Diagram of AL1, AL3, AL5

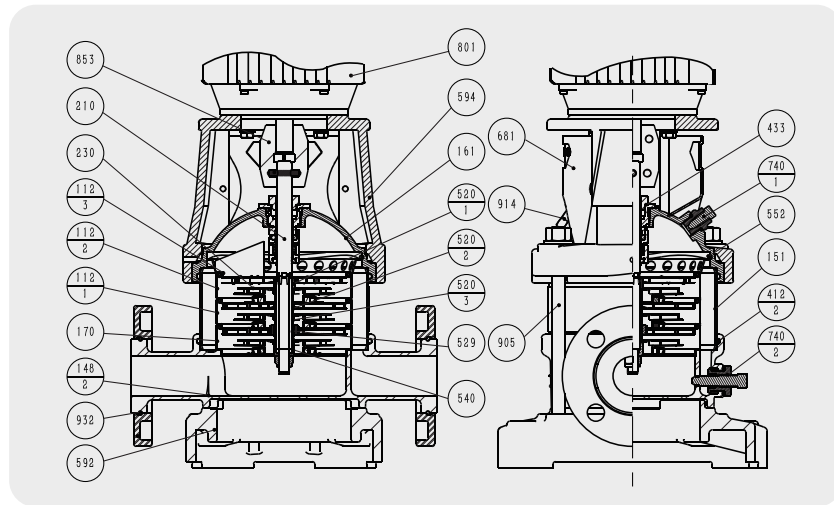

Serial No.	Name	Material
112-1	Deflector with bearing	304
112-2	Deflector	304
112-3	Outlet deflector	304
148-2	Pump seat	304
151	Outer cylinder	304
161	Spherical lining	ZG07Cr19Ni9
170	Inlet deflector	304
210	Spline shaft	304
230	Impeller	304
412-2	O-ring	FPM
433	Mechanical seal	YG6, FPM
520-1	Spacer sleeve	304
520-2	Long round sleeve	304
520-3	Short round sleeve	304
529	Bearing inner race	YG8
540	Bushing	304
552	Wave spring	304
592	Base	HT200
594	Ball lining motor seat	HT200
681	Protection sheet	ABS
740-1	Vent valve	304
740-2	Water discharge and pressure regulating assembly	304
801	Motor	Standard vertical motor
853	Coupling	F0212J
905	Pull rod	45#
932	Wire retaining ring	304

Serial No.	Name	Material
112-1	Deflector with bearing	304
112-2	Deflector	304
112-3	Outlet deflector	304
148-2	Pump seat	304
151	Outer cylinder	304
161	Spherical lining	QT400-18
170	Inlet deflector	304
210	Spline shaft	304
230	Impeller	304
412-2	O-ring	FPM
433	Mechanical seal	YG6, FPM
520-1	Spacer sleeve	304
520-2	Long round sleeve	304
520-3	Short round sleeve	304
529	Bearing inner race	YG8
540	Bushing	304
552	Wave spring	304
594	Ball lining motor seat	HT200
681	Protection sheet	ABS
740-1	Vent valve	304
740-2	Water discharge and pressure regulating assembly	304
801	Motor	Standard vertical motor
853	Coupling	F0212J
905	Pull rod	45#
932	Wire retaining ring	304

Explosion View of AL1, 3, 5

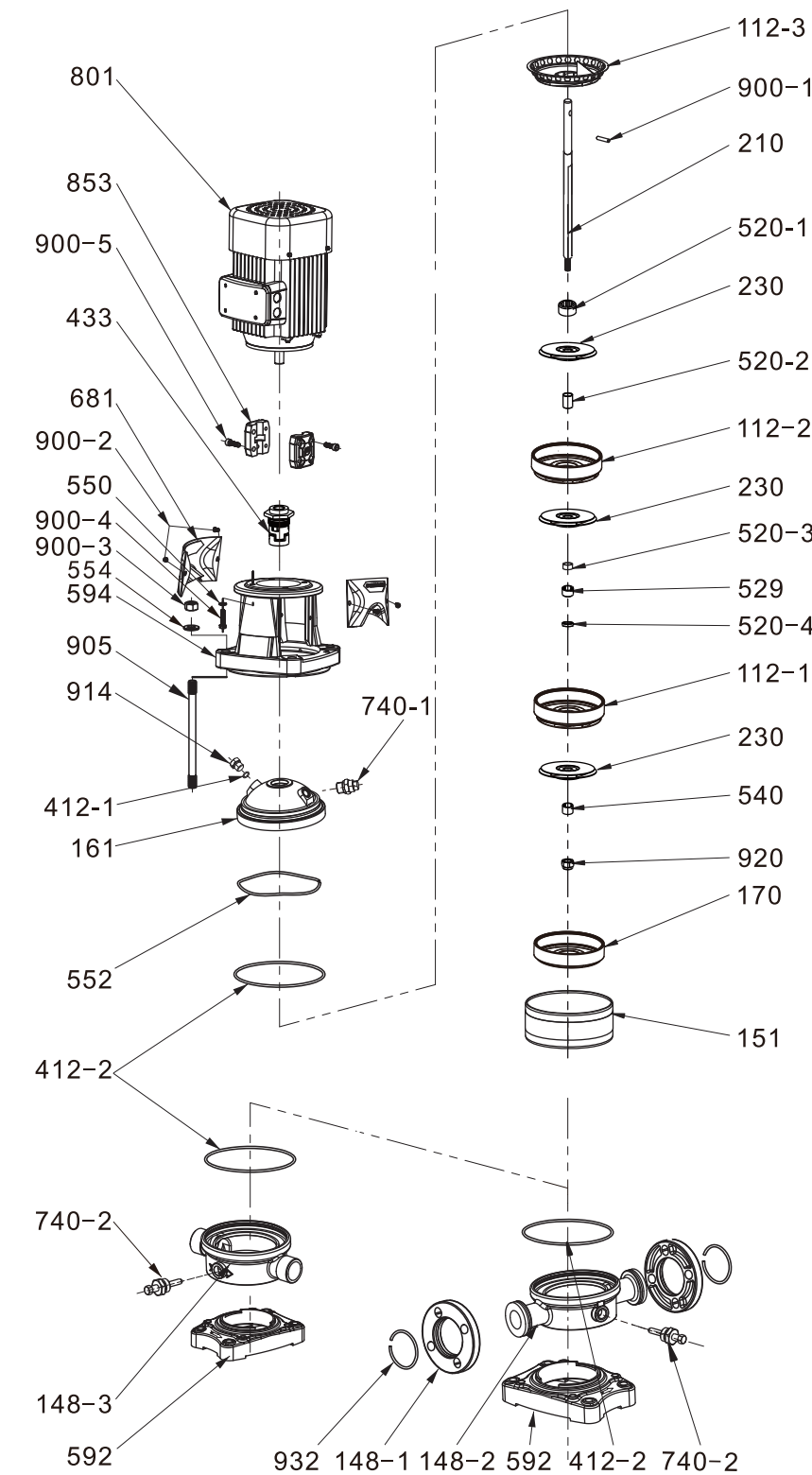

Serial No.	Name
112-1	Deflector with bearing
112-2	Deflector
112-3	Outlet deflector
148-1	Lap-joint flange
148-2	Lap-joint flange pump seat
148-3	Threaded pump seat
151	Outer cylinder
161	Spherical lining
170	Inlet deflector
210	Spline shaft
230	Impeller
412-1	O-ring $\phi 11.8 \times 2.65$
412-2	O-ring $\phi 136 \times 3.55$
433	Mechanical seal
520-1	Spacer sleeve
520-2	Long round sleeve
520-3	Short round sleeve I
520-4	Short round sleeve II
529	Bearing inner race
540	Bushing
550	Flat washer 6
552	Wave spring
554	Flat washer $d13 \times d24 \times 2.5$
592	Base
594	Ball lining motor seat
681	Protection sheet
740-1	Vent valve
740-2	Water discharge and pressure regulating assembly
801	Motor
853	Coupling half I
900-1	Cylindrical pin $\phi 5 \times 25$
900-2	Cross recessed pan head screw M5 $\times 8$
900-3	Type I hexagon nut M12
900-4	Hexagon head bolt - full thread
900-5	Hexagon socket head cap screw
905	Pull rod
914	Screwed plug G1/4
920	Type I non-metallic insert hexagon lock nut M8 (anti-thread)
932	Wire retaining ring

Explosion View of ALT1, 3, 5

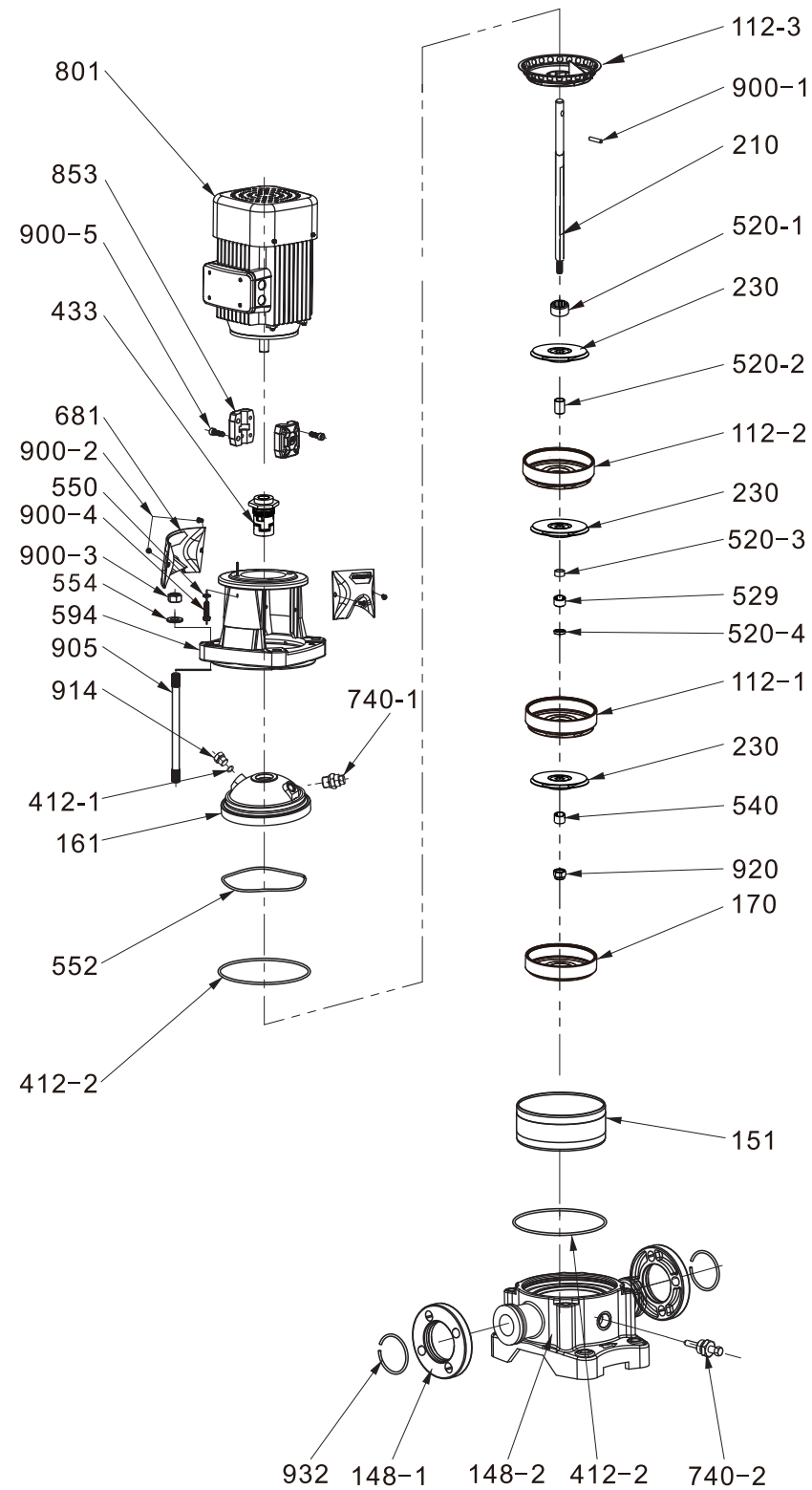

Serial No.	Name
112-1	Deflector with bearing
112-2	Deflector
112-3	Outlet deflector
148-1	Lap-joint flange
148-2	Pump seat
151	Outer cylinder
161	Spherical lining
170	Inlet deflector
210	Spline shaft
230	Impeller
412-1	O-ring $\phi 11.8 \times 2.65$
412-2	O-ring $\phi 136 \times 3.55$
433	Mechanical seal
520-1	Spacer sleeve
520-2	Long round sleeve
520-3	Short round sleeve I
520-4	Short round sleeve II
529	Bearing inner race
540	Bushing
550	Flat washer 6
552	Wave spring
554	Flat washer d13 x d24 x 2.5
594	Ball lining motor seat
681	Protection sheet
740-1	Vent valve
740-2	Water discharge and pressure regulating assembly
801	Motor
853	Coupling half I
900-1	Cylindrical pin $\phi 5 \times 25$
900-2	Cross recessed pan head screw M5 x 8
900-3	Type I hexagon nut M12
900-4	Hexagon head bolt - full thread
900-5	Hexagon socket head cap screw
905	Pull rod
914	Screwed plug G1/4
920	Type I non-metallic insert hexagon lock nut M8 (anti-thread)
932	Wire retaining ring

Structural Diagram of AL(T)10, 15, 20

Structural diagram of AL10, AL 15, AL20

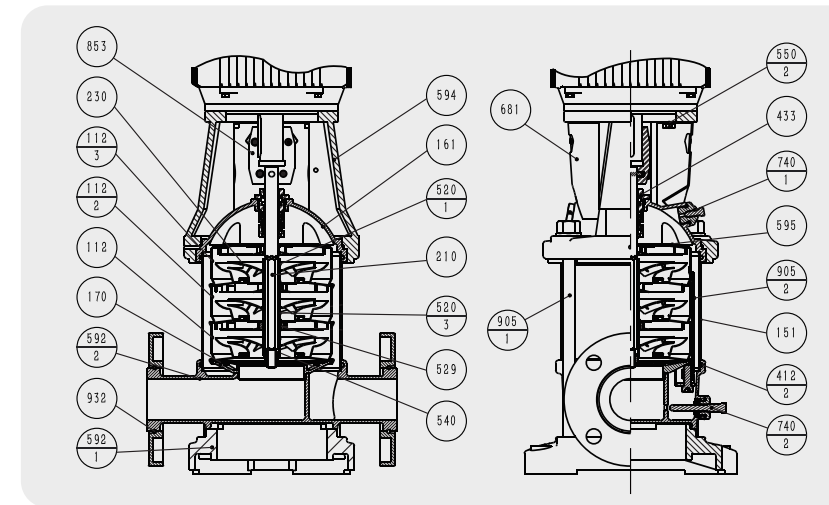

Serial No.	Name	Material
112-1	Deflector with bearing	304
112-2	Deflector	304
112-3	Outlet deflector	304
151	Outer cylinder	304
161	Spherical lining	304
170	Inlet deflector	304
210	Spline shaft	304
230	Impeller	304
412-2	O-ring	NBR
433	Mechanical seal	YG6, FPM
520-1	Spacer sleeve	304
520-2	Long round sleeve	304
520-3	Short round sleeve	304
529	Bearing inner race	YG8
540	Bushing	304
592-1	Base	HT200
592-2	Pump seat	HT200
594	Ball lining motor seat	HT200
595	Compression nail	FPM
681	Protection sheet	ABS
740-1	Vent valve	304
740-2	Water discharge and pressure regulating assembly	304
801	Motor	Standard vertical motor
853	Coupling	F0212J
905-1	Pull rod	45#
905-2	Pull plate	304
932	Wire retaining ring	304

Structural diagram of ALT10, ALT15, ALT20

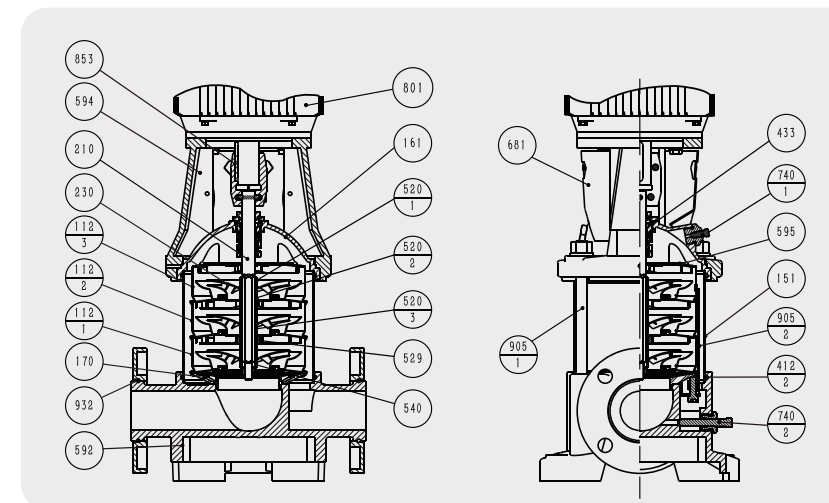

Serial No.	Name	Material
112-1	Deflector with bearing	304
112-2	Deflector	304
112-3	Outlet deflector	304
151	Outer cylinder	304
161	Spherical lining	QT400-18
170	Inlet deflector	304
210	Spline shaft	304
230	Impeller	304
412-2	O-ring	NBR
433	Mechanical seal	YG6, FPM
520-1	Spacer sleeve	304
520-2	Long round sleeve	304
520-3	Short round sleeve	304
529	Bearing inner race	YG8
540	Bushing	304
592	Pump seat	HT200
594	Ball lining motor seat	HT200
595	Compression nail	FPM
681	Protection sheet	ABS
740-1	Vent valve	304
740-2	Water discharge and pressure regulating assembly	304
801	Motor	Standard vertical motor
853	Coupling	F0212J
905-1	Pull rod	45#
905-2	Pull plate	304
932	Wire retaining ring	304

Explosion View of AL10, 15, 20

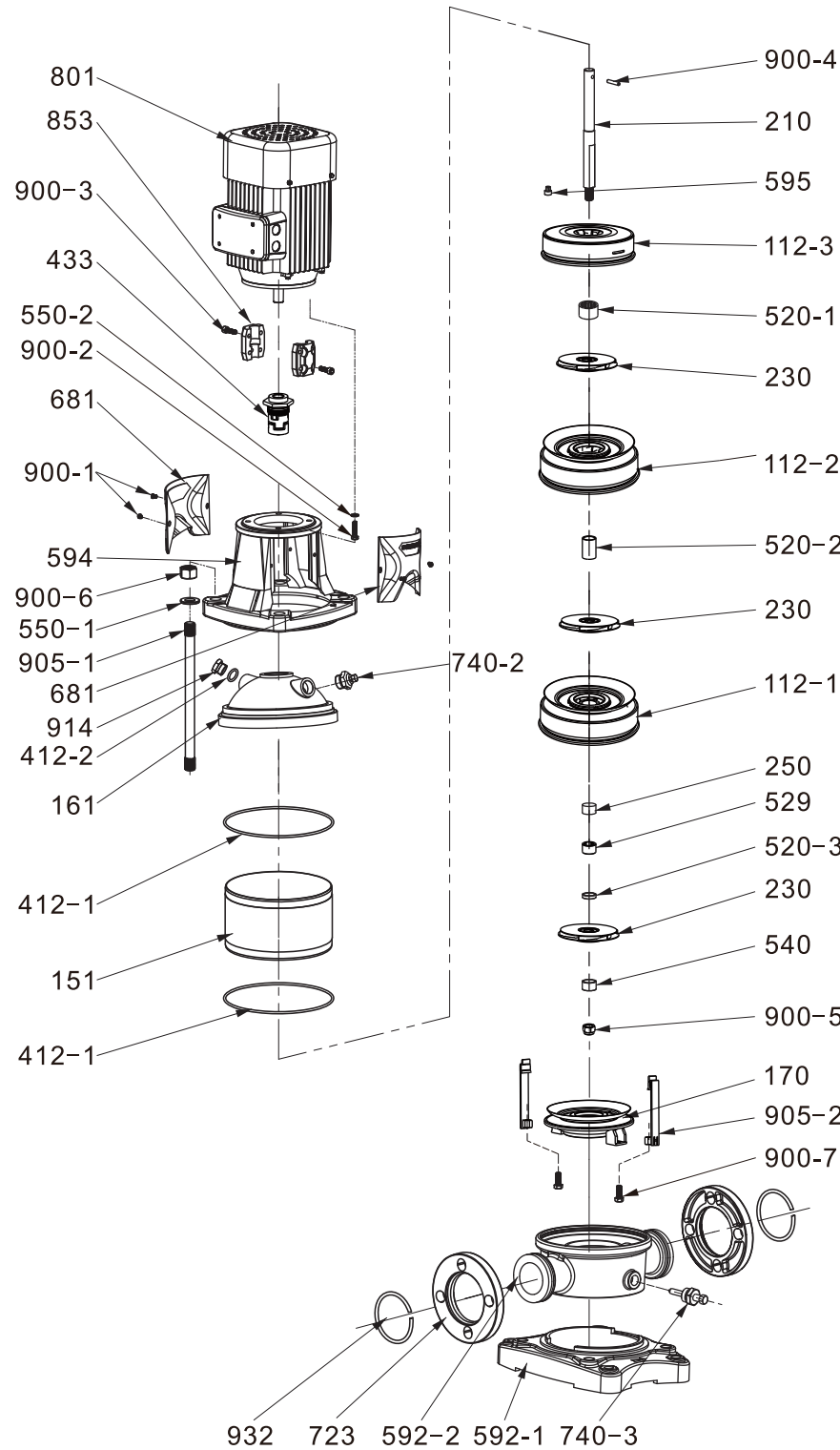

Serial No.	Name
112-1	Deflector with bearing
112-2	Deflector
112-3	Outlet deflector
151	Outer cylinder
161	Spherical lining
170	Inlet deflector
210	Spline shaft
230	Impeller
250	Short round sleeve II (Opel shaft)
412-1	O-ring $\phi 167.5 \times 3.55$
412-2	O-ring $\phi 17 \times 2.65$
433	Mechanical seal
520-1	Spacer sleeve
520-2	Long round sleeve I (Opel shaft)
520-3	Short round sleeve I (Opel shaft)
529	Bearing inner race
540	Bushing (Opel shaft)
550-1	Flat washer 16
550-2	Flat washer 6
592-1	Base
592-2	Pump seat
594	Ball lining motor seat
595	Compression nail
681	Protection sheet
723	Lap-joint flange
740-2	Vent valve
740-3	Water discharge and pressure regulating assembly
801	Motor
853	Coupling half
900-1	Cross recessed pan head screw M5 \times 8
900-2	Hexagon head bolt - full thread M6 \times 25
900-3	Hexagon socket head cap screw M6 \times 25
900-4	Cylindrical pin $\phi 5 \times 28$
900-5	Type I non-metallic insert hexagon lock nut M10LH
900-6	Type I hexagon nut M16
900-7	Hexagon socket head cap screw M8 \times 25
905-1	Pull rod
905-2	Pull plate
914	Screwed plug
932	Wire retaining ring

Explosion View of ALT10, 15, 20

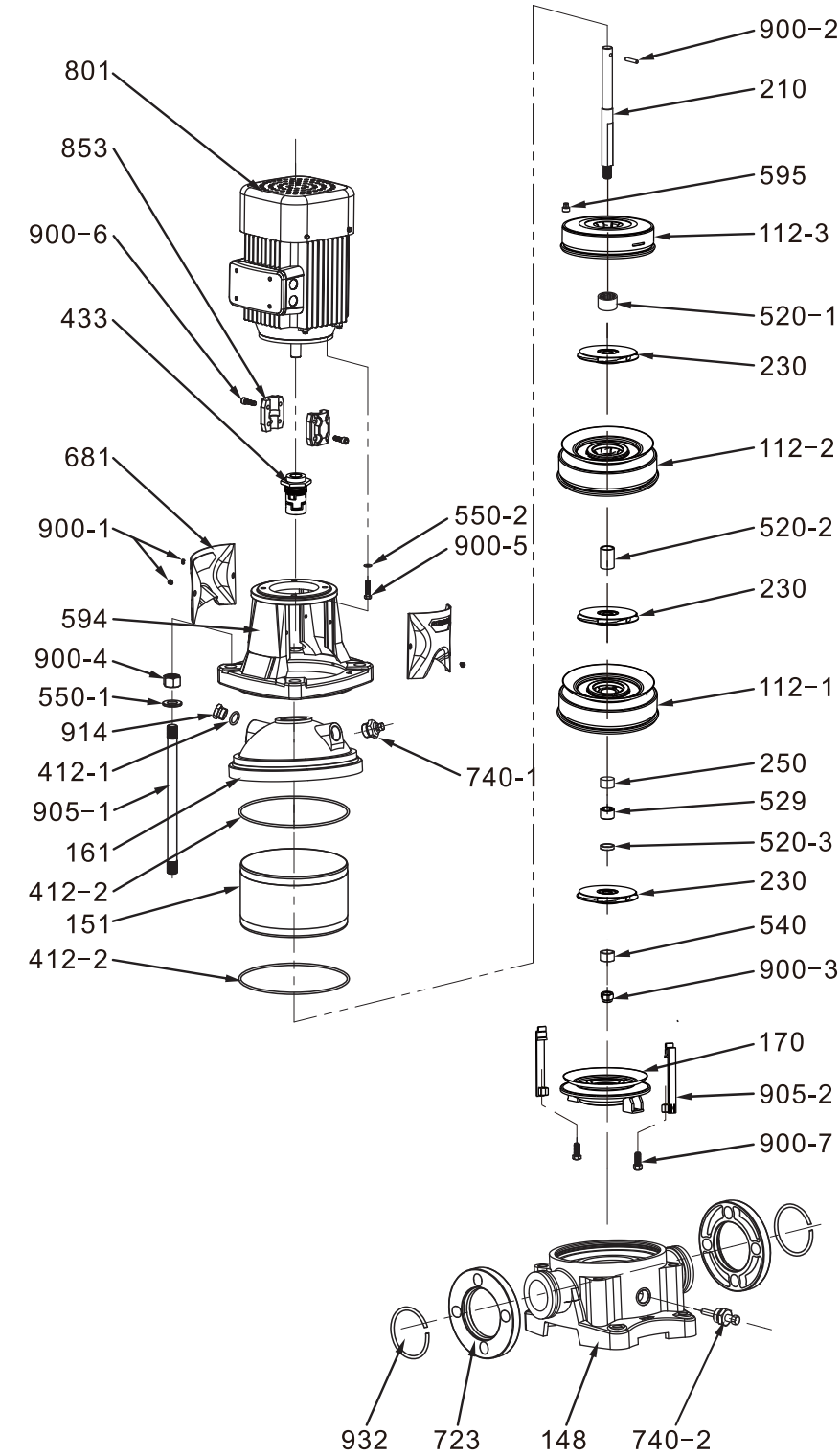

Serial No.	Name
112-1	Deflector with bearing
112-2	Deflector
112-3	Outlet deflector
148	Pump seat
151	Outer cylinder
161	Spherical lining
170	Inlet deflector
210	Spline shaft
230	Impeller
250	Short round sleeve II (Opel shaft)
412-1	O-ring $\phi 17 \times 2.65$
412-2	O-ring $\phi 167.5 \times 3.55$
433	Mechanical seal
520-1	Spacer sleeve
520-2	Long round sleeve I (Opel shaft)
520-3	Short round sleeve I (Opel shaft)
529	Bearing inner race
540	Bushing (Opel shaft)
550-1	Flat washer 16
550-2	Flat washer 6
594	Ball lining motor seat
595	Compression nail
681	Protection sheet
723	Lap-joint flange
740-1	Vent valve
740-2	Water discharge and pressure regulating assembly
801	Motor
853	Coupling half
900-1	Cross recessed pan head screw M5 \times 8
900-2	Cylindrical pin $\phi 5 \times 28$
900-3	Type I non-metallic insert hexagon lock nut M10LH
900-4	Type I hexagon nut M16
900-5	Hexagon head bolt - full thread M6 \times 25
900-6	Hexagon socket head cap screw M6 \times 25
900-7	Hexagon socket head cap screw M8 \times 25
905-1	Pull rod
905-2	Pull plate
914	Screwed plug
932	Wire retaining ring

Performance Curve of AL(T)1

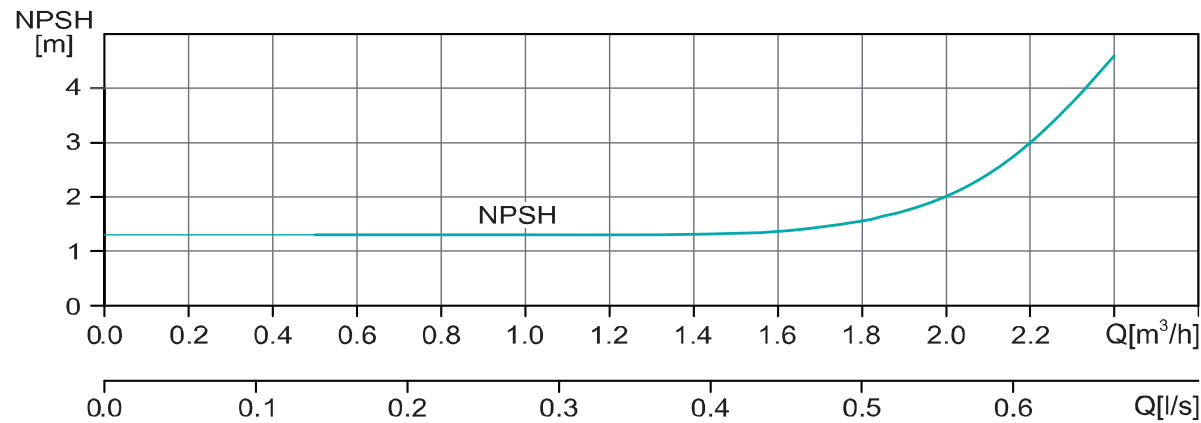
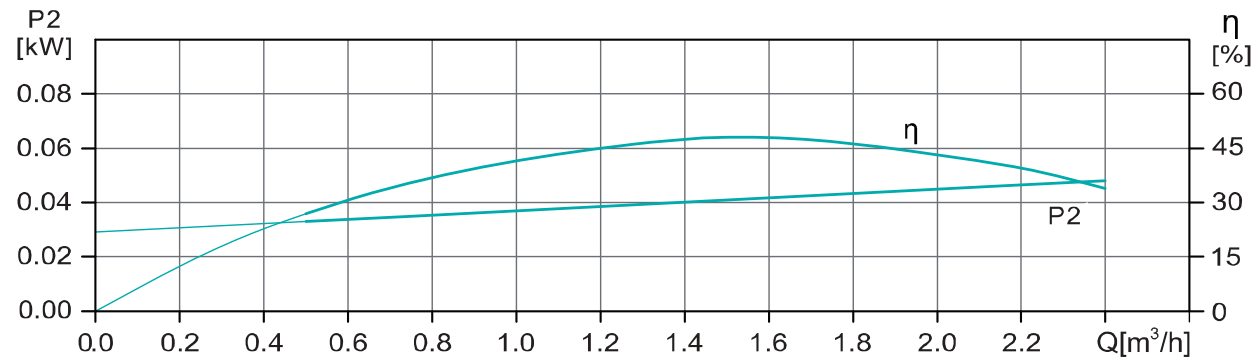
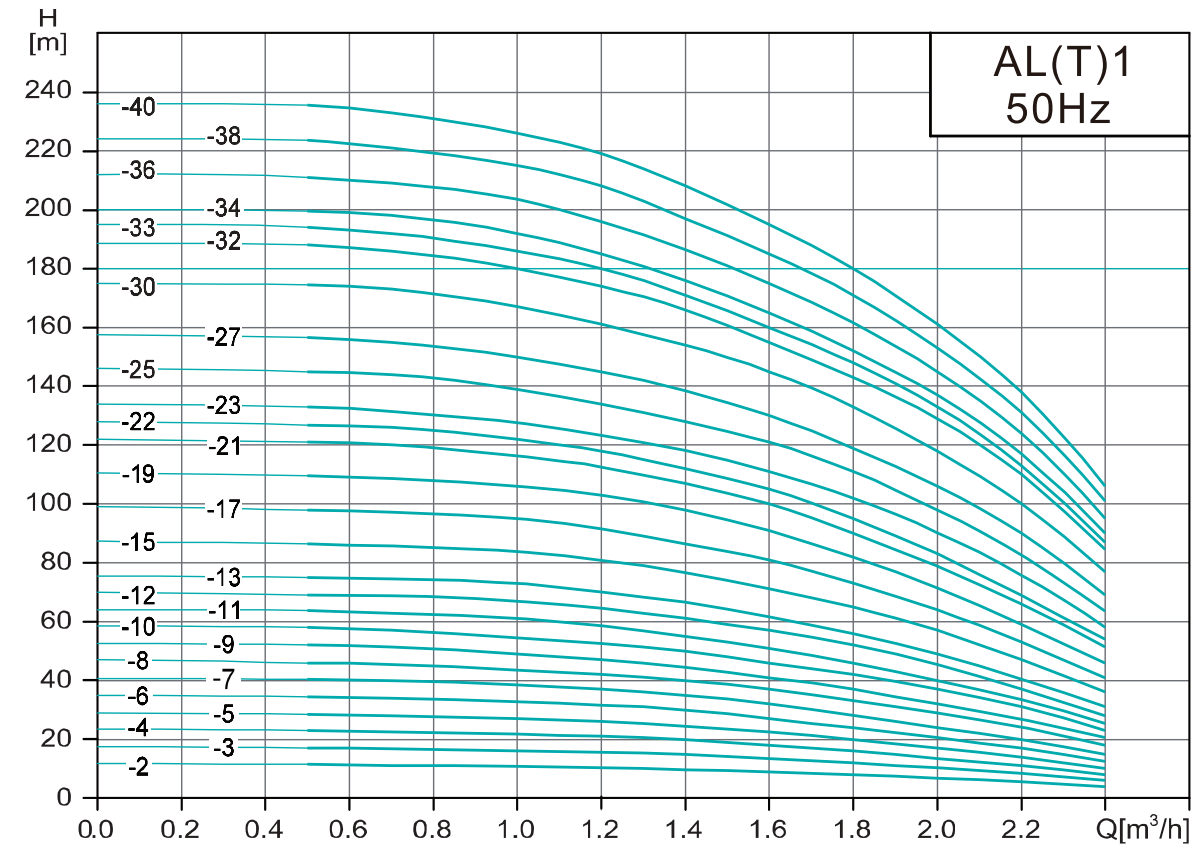

Parameter Table

Model	Motor power(kw)	Q (m³/h)	0	0.5	0.7	1	1.2	1.4	1.6	1.8	2	2.2	2.4	Range of pumping head (m)
AL(T)1-2	0.37	H (m)	11.8	11.5	11.2	10.5	10.3	9.7	9	8	6.8	5.5	4	4~11.8
AL(T)1-3	0.37		17.5	17	16.8	16	15.6	14.8	13.5	12	10	8.5	6	6~17.5
AL(T)1-4	0.37		23.5	23	22.5	21.5	21	19.8	18	16	13.5	11	8	8~23.5
AL(T)1-5	0.37		29	28.5	28	27	26	24.5	22.5	20	17	14	10	10~29
AL(T)1-6	0.37		35	34.5	34	32.5	31.5	30	27	24	20.5	17	12.5	12.5~35
AL(T)1-7	0.37		41	40.5	40	39	37	35	32	28	24	20	15	15~41
AL(T)1-8	0.55		47	46	45.5	43.5	42	40	37	33	29	24.5	18	18~47
AL(T)1-9	0.55		52.5	52	51.5	49	47	44.5	41	37	32	27	20.5	20.5~52.5
AL(T)1-10	0.55		58.5	58	57	55	52.5	50	46	42	37	31	23	23~58.5
AL(T)1-11	0.55		64	63.5	63	61	58.5	55	51	46	40	33.5	25.5	25.5~64
AL(T)1-12	0.75		70	69	68.5	67	64.5	61	57	52	45.5	37	28	28~70
AL(T)1-13	0.75		75.5	75	74.5	73	70	66.5	61.5	56	49	40.5	31	31~75.5
AL(T)1-15	0.75		87.5	86.5	85.5	84	81	76.5	71	65	57	47	36	36~87.5
AL(T)1-17	1.1		99	98	97	95	91.5	86.5	81	73	64	53	41	41~99
AL(T)1-19	1.1		110	109	108	106	103	98	91	82	72	59	46	46~110
AL(T)1-21	1.1		122	121	120	117	113	107	100	90	79	66	51.5	51.5~122
AL(T)1-22	1.1		128	127	126	122	118	112	105	95	83	69	54	54~128
AL(T)1-23	.15		134	133	132	128	123	118	111	102	90.5	76.5	58	58~134
AL(T)1-25	1.5		146	145	144	139	134	128	121	111	98	83	63	63~146
AL(T)1-27	1.5		158	157	155	150	145	138	130	119	106	90	69	69~158
AL(T)1-30	1.5	175	174	172	167	161	154	145	133	118	100	77	77~175	
AL(T)1-32	2.2	189	188	186	180	174	166	155	143	129	110	85	85~189	
AL(T)1-33	2.2	195	194	192	186	180	171	160	148	133	113	87	87~195	
AL(T)1-34	2.2	200	199	198	192	185	176	165	152	137	117	90	90~200	
AL(T)1-36	2.2	212	211	209	203	196	186	175	161	145	124	95	95~212	
AL(T)1-38	2.2	225	224	221	215	208	197	185	171	153	131	101	101~225	
AL(T)1-40	2.2	237	236	233	226	219	208	195	180	161	106	106	106~237	

Performance Curve of AL(T)3

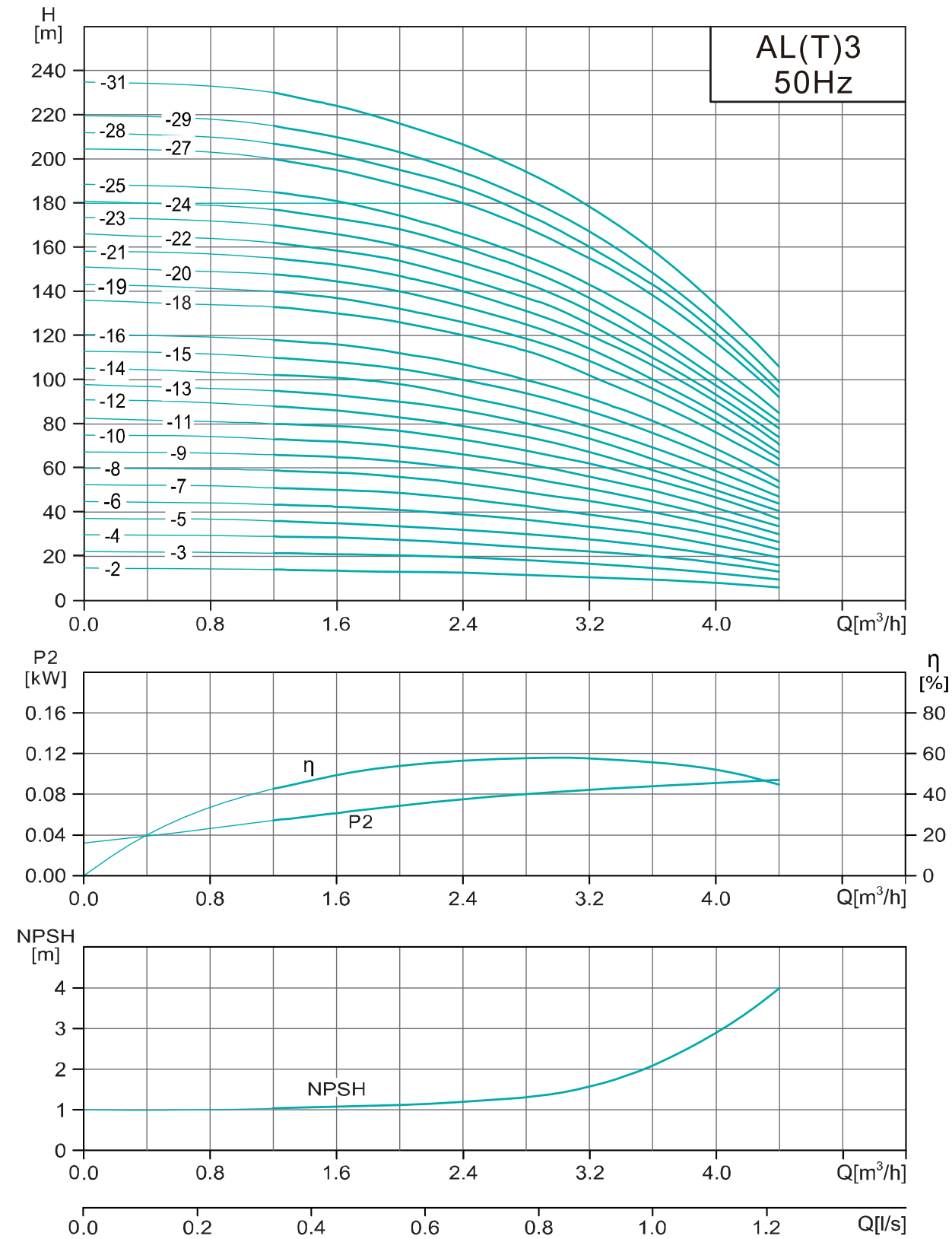

Parameter Table

Model	Motor power(kw)	Q (m³/h)	0	1.2	1.6	2	2.4	2.8	3	3.2	3.6	4	4.4	Range of pumping head (m)
AL(T)3-2	0.37	H (m)	14.7	14	13.5	13	12.5	11.5	11	10.5	9.5	8	6	6~14.7
AL(T)3-3	0.37		22.2	21.5	21	20.5	19.5	18	17	16.5	15	12.5	9.5	9.5~22.2
AL(T)3-4	0.37		29.7	29	28.5	27.5	26	24	23	22	20	17	13	13~29.7
AL(T)3-5	0.55		37.2	36	35	33.5	32	30	29	28	25	21	16	16~37.2
AL(T)3-6	0.55		45	43.5	42.5	41	39	36.5	35	33.5	30	25	19.5	19.5~45
AL(T)3-7	0.75		52.5	51	50	49	46	43	41	39.5	35	30	23	23~52.5
AL(T)3-8	0.75		60	58.5	58	56	53	49	47	45	40	34	26.5	26.5~60
AL(T)3-9	1.1		67.5	66	65	63	60	56	53	51	45	38	30	30~67.5
AL(T)3-10	1.1		75	73	72	70	66	61	59	56	50	42	33.5	33.5~75
AL(T)3-11	1.1		82.5	80	79	77	73	68	65	62	55	47	37	37~82.5
AL(T)3-12	1.1		90	88	86	83	79	74	71	67	59	50	40.5	40.5~90
AL(T)3-13	1.5		98	95	93	90	86	80	77	73	64	54	44	44~98
AL(T)3-14	1.5		105	102	101	98	92.5	86	83	78	69	58	47	47~105
AL(T)3-15	1.5		113	110	108	105	100	94	90	86	76	64	51	51~113
AL(T)3-16	1.5		120	118	116	112	107	100	96	92	81	69	54	54~120
AL(T)3-18	2.2		136	133	130	126	120	113	108	102	90	76	61	61~136
AL(T)3-19	2.2		143	140	137	132	126	119	114	108	96	82	64	64~143
AL(T)3-20	2.2		151	148	144	140	133	125	120	114	100	85	67	67~151
AL(T)3-21	2.2		158	155	152	147	140	131	126	120	106	90	71	71~158
AL(T)3-22	2.2		166	162	158	154	146	137	132	125	110	93	74	74~166
AL(T)3-23	2.2		173	170	166	161	153	144	138	131	115	97	78	78~173
AL(T)3-24	2.2		181	177	173	168	160	150	144	137	120	101	81	81~181
AL(T)3-25	3		188	185	181	175	166	156	150	142	125	105	85	85~188
AL(T)3-27	3		204	200	195	188	180	169	162	155	138	117	92	92~204
AL(T)3-28	3		212	207	202	195	187	175	168	160	143	121	95	95~212
AL(T)3-29	3		220	215	210	203	194	182	175	167	148	126	99	99~220
AL(T)3-31	3		235	230	224	216	207	194	187	178	159	134	106	106~235

Performance Curve of AL(T)5

Parameter Table

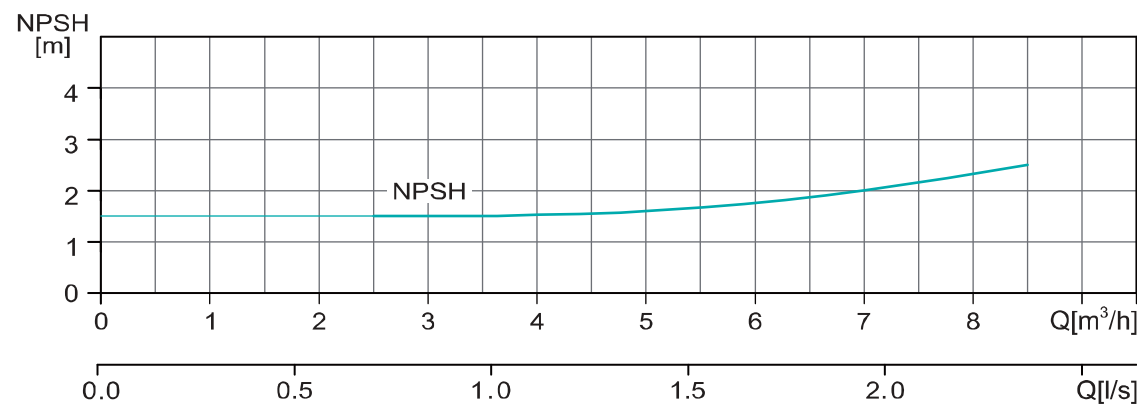
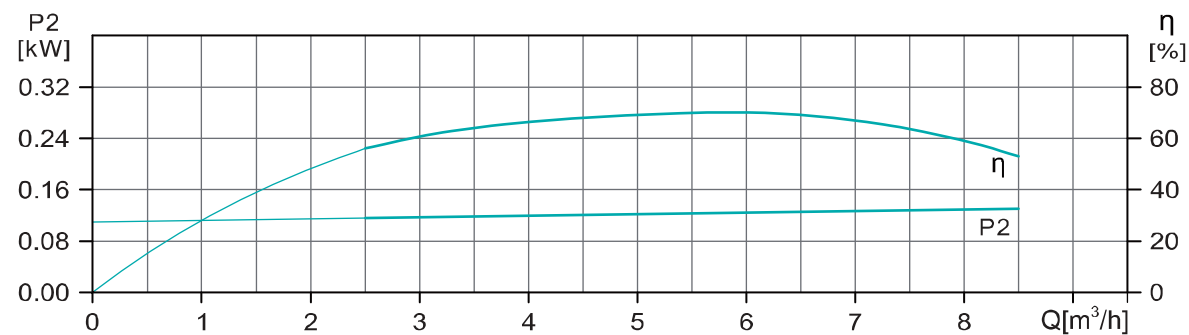
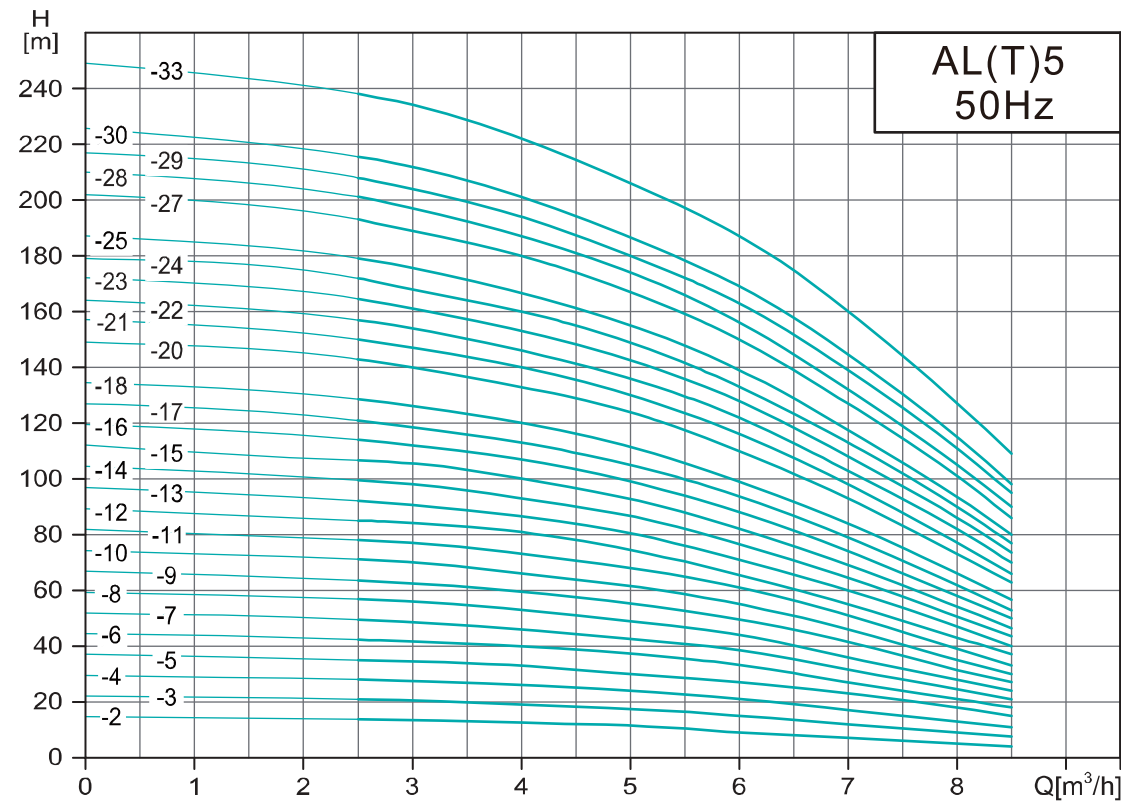

Model	Motor power(kw)	Q (m³/h)	0	2.5	3	4	5	6	7	8	8.5	Range of pumping head (m)
AL(T)5-2	0.37	H (m)	14.7	13.5	13.3	12.5	11.5	9	7	5	4	6~14.7
AL(T)5-3	0.55		22.1	21	20.5	19	17.5	15	12	9	7.5	9.5~22.2
AL(T)5-4	0.55		29.5	28	27.5	26	24	21	17	13	11	13~29.7
AL(T)5-5	0.75		37	35	34.5	33	30	27	23	18	15	16~37.2
AL(T)5-6	1.1		44.5	42	41.5	40	37	33	27	21	18	19.5~45
AL(T)5-7	1.1		52	49.5	48.5	46	42.5	38.5	31.5	24.5	21	23~52.5
AL(T)5-8	1.1		59	57	56	53	49	44	36	28	24	26.5~60
AL(T)5-9	1.5		67	64	63	60	55	49.5	41.5	31.5	27	30~67.5
AL(T)5-10	1.5		74.5	71	70	66	62	55	46	35	30	33.5~75
AL(T)5-11	1.5		82	78	77	73	68	61	51	39	33	37~82.5
AL(T)5-12	2.2		89.5	85	84	81	74.5	66	55	43	37	40.5~90
AL(T)5-13	2.2		97	92	91	87	80	71	60	47	40	44~98
AL(T)5-14	2.2		104	100	98	93	87	77	65	51	43.5	47~105
AL(T)5-15	2.2		112	107	106	100	93	82	69	54	46.5	51~113
AL(T)5-16	2.2		119	114	112	107	99	88	74	58	50	54~120
AL(T)5-17	3		127	121	118.5	113	105	94	79	62	53	61~136
AL(T)5-18	3		134	128	126	120	111	99	84	66	56	64~143
AL(T)5-20	3		149	143	140	133	124	110	93	73	63	67~151
AL(T)5-21	3		157	150	147	140	130	116	98	77	66	71~158
AL(T)5-22	4		164	157	154	146	136	122	103	82	70	74~166
AL(T)5-23	4		172	165	161	153	142	128	108	86	74	78~173
AL(T)5-24	4		179	172	168	160	149	133	113	90	77	81~181
AL(T)5-27	4		202	193	189	180	168	150	127	101	86	85~188
AL(T)5-28	4		210	201	197	187	174	156	132	105	90	92~204
AL(T)5-29	5.5		217	208	204	194	180	163	139	111	95	95~212
AL(T)5-30	5.5		225	216	212	201	186	169	144	115	98	99~220
AL(T)5-33	5.5		249	238	234	222	206	187	160	127	109	106~235

Performance Curve of AL(T)10

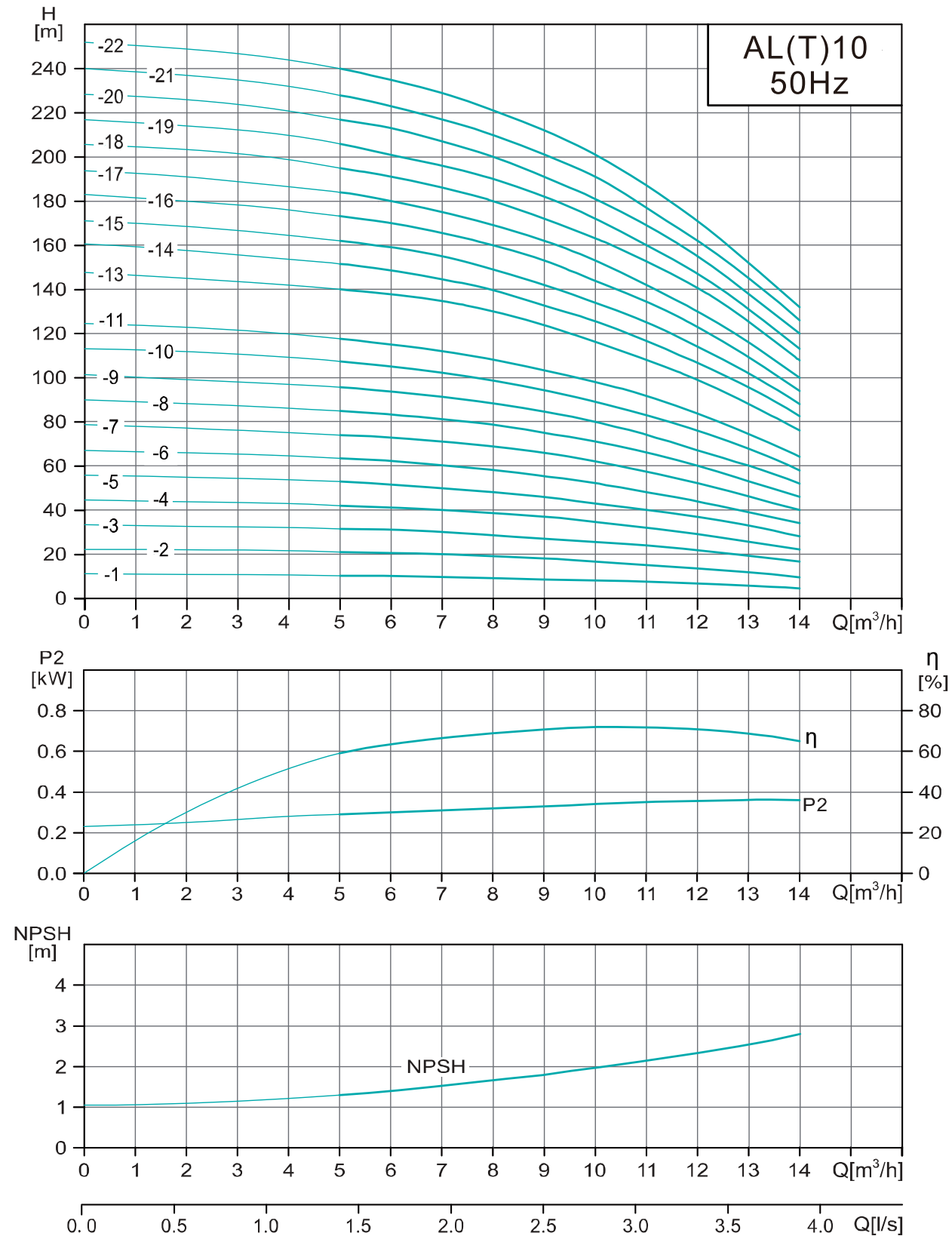

Parameter Table

Model	Motor power(kw)	Q (m³/h)	0	5	6	8	10	12	14	Range of pumping head (m)
AL(T)10-1	0.75	H (m)	11	10.2	10	9	8	7	4.5	4.5~11
AL(T)10-2	0.75		22.2	21	20.5	19	16.5	13.5	9.5	9.5~22.2
AL(T)10-3	1.1		33.3	31.5	31	28.5	25.5	22	16.5	16.5~33.3
AL(T)10-4	1.5		44.5	42	41	38	34	29	22	22~44.5
AL(T)10-5	2.2		56	52.5	51	48	43	37	28	28~56
AL(T)10-6	2.2		67	63	62	58	52	44	34	34~67
AL(T)10-7	3		78.5	74	73	69	62	52	40	40~78.5
AL(T)10-8	3		90	85	84	79	71	60	46	46~90
AL(T)10-9	4		101.5	96	94	89	80	67	52	52~101.5
AL(T)10-10	4		113	107	105	98	89	76	58	58~113
AL(T)10-11	4		124	118	115	108	98	84	64	64~124
AL(T)10-12	4.5		137	129	127	119	107	91	70	70~137
AL(T)10-13	5.5		147	140	138	130	116	99	76	76~147
AL(T)10-14	5.5		160	151	148	139	125	106	82	82~160
AL(T)10-15	5.5		171	162	159	149	134	114	88	88~171
AL(T)10-16	7.5		183	173	170	159	144	123	94	94~183
AL(T)10-17	7.5		194	184	180	169	153	130	100	100~194
AL(T)10-18	7.5		205	195	191	180	163	141	108	108~205
AL(T)10-19	7.5		217	206	201	190	172	147	113	113~217
AL(T)10-20	7.5		228	217	213	200	181	155	120	120~228
AL(T)10-21	7.5		240	228	223	210	191	162	126	126~240
AL(T)10-22	11		250	240	235	221	201	171	132	132~250

Performance Curve of AL(T)15

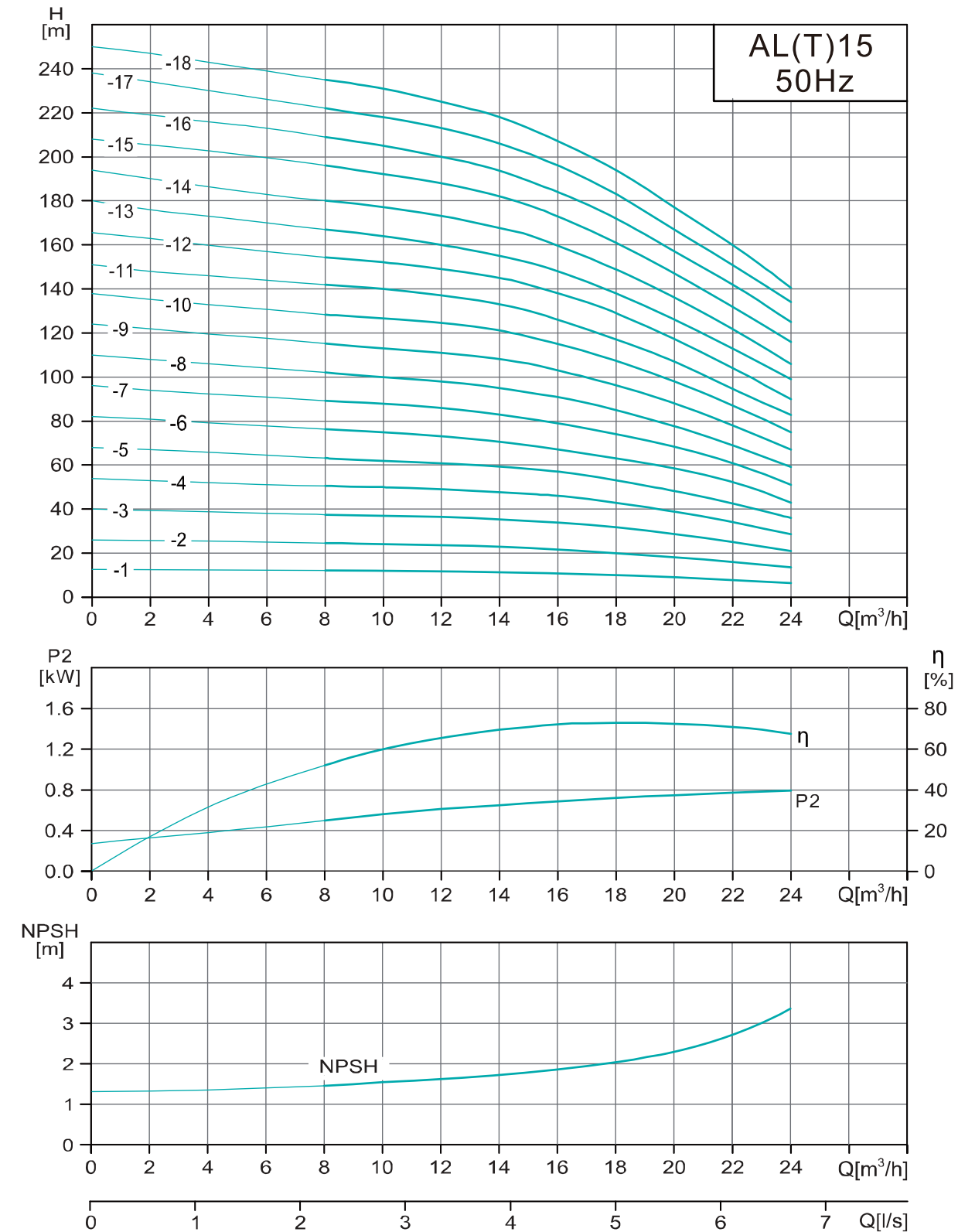

Parameter Table

Model	Motor power(kw)	Q (m³/h)	0	8	10	12	14	15	16	18	20	22	24	Range of pumping head (m)
AL(T)15-1	1.1	H (m)	12.6	12.2	12	11.8	11.5	11	10.5	10	9	8	6.5	6.5~12.6
AL(T)15-2	2.2		26	24.5	24	23.5	23	22.5	21.5	20	18	16	13.5	13.5~26
AL(T)15-3	3		40	37.5	37	36.5	35.5	34.5	34	32	29	25	21	21~40
AL(T)15-4	4		54	50.5	50	49	47.5	47	46	43	39	34	28.5	28.5~54
AL(T)15-5	4		68	63	62	61	59	58	57	53	48	42.5	36	36~68
AL(T)15-6	5.5		82	76	75	73	71	69	67	63	58	52	43	43~82
AL(T)15-7	5.5		96	89	88	86	83	81	79	74	68	61	51	51~96
AL(T)15-8	7.5		110	102	100	98	95	93	91	85	78	69	59	59~110
AL(T)15-9	7.5		124	115	113	111	108	106	103	96	88	78	67	67~124
AL(T)15-10	11		138	128	126	124	121	118	115	107	98	87	75	75~138
AL(T)15-11	11		151	142	140	137	133	130	126	117	107	95	83	83~151
AL(T)15-12	11		166	154	152	149	145	142	138	129	117	104	90	90~166
AL(T)15-13	11		180	167	164	160	155	152	148	138	126	113	99	99~180
AL(T)15-14	11		194	180	177	173	168	165	160	149	136	122	106	106~194
AL(T)15-15	15		208	196	192	188	182	178	173	161	147	132	116	116~208
AL(T)15-16	15		222	209	205	200	194	189	184	172	157	142	125	125~222
AL(T)15-17	15		236	222	218	213	206	201	196	183	167	151	132	132~236
AL(T)15-18	15		250	235	231	225	218	213	207	194	177	160	141	141~250

Performance Curve of AL(T)20

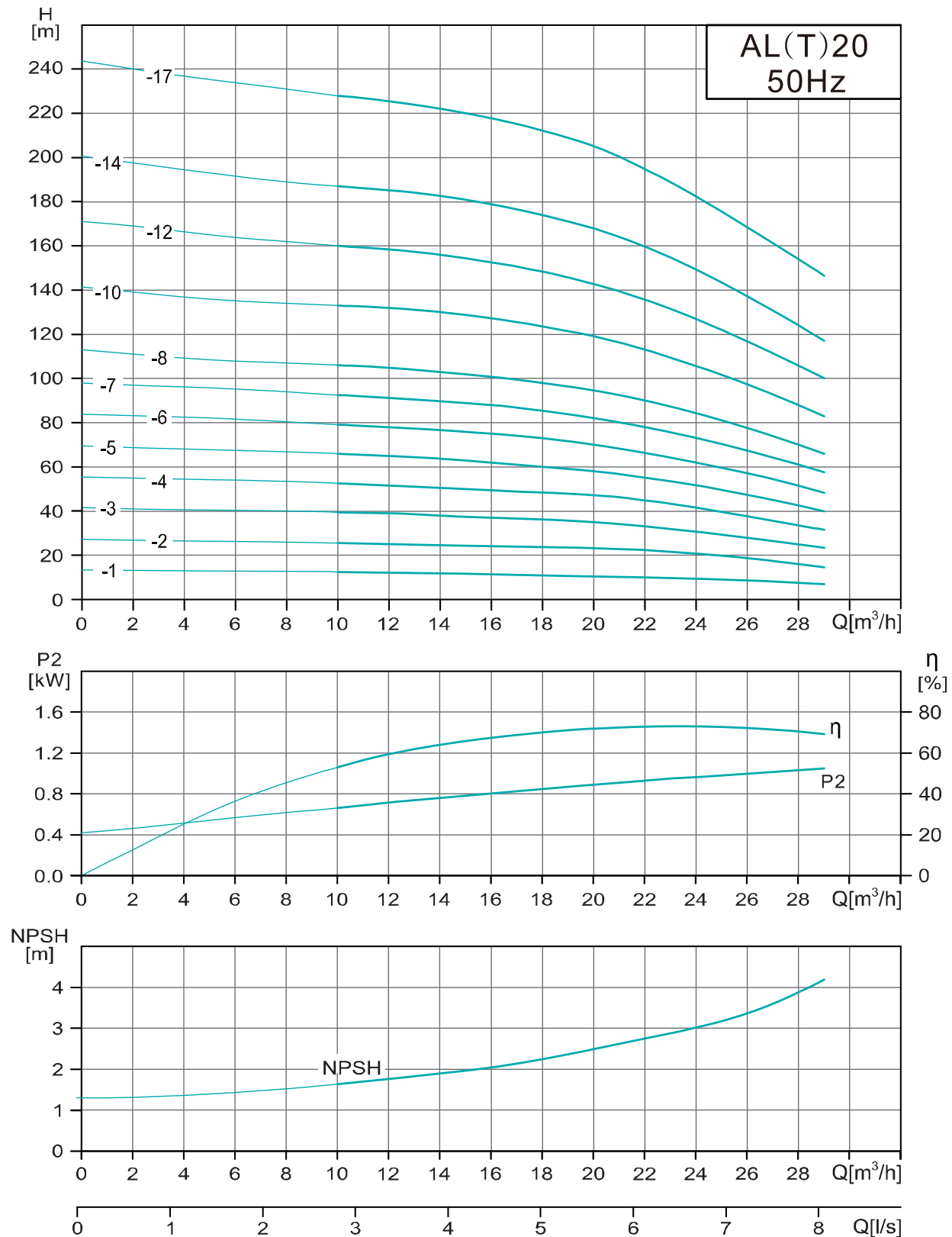

Parameter Table

Model	Motor power(kW)	Q (m³/h)	0	10	12	14	16	18	20	22	24	26	28	29	Range of pumping head (m)
AL(T)20-1	1.1	H (m)	13.3	12.5	12.3	12	11.5	11	10.5	10	9.5	9	8	7	7~13.3
AL(T)20-2	2.2		27.2	25.5	25	24.5	24	23.7	23	22	20.5	18	16	14.5	14.5~27.2
AL(T)20-3	4		41.5	39.5	39	38	37	36	35	33	31	28	25	23.5	23.5~41.5
AL(T)20-4	5.5		55.5	52.5	51	50	49	48.5	47	45	41.5	37	33	31.5	31.5~55.5
AL(T)20-5	5.5		69.5	66	65	64	62	60	58	55	51	47	42	40	40~69.5
AL(T)20-6	7.5		84	79	78	77	75	73	70	66	62	58	52	48	48~84
AL(T)20-7	7.5		98	92.5	91	90	88	85	82	78	73	68	61	57.5	57.5~98
AL(T)20-8	11		113	106	105	103	101	98	95	90	84	77	70	66	66~113
AL(T)20-10	11		141	133	132	130	127	123	119	113	106	97	88	83	83~141
AL(T)20-12	15		171	160	158	156	153	149	143	137	127	117	106	100	100~171
AL(T)20-14	15		200	187	185	183	179	174	168	160	149	137	124	117	117~200
AL(T)20-17	18.5		244	228	225	222	218	212	205	195	182	168	154	147	147~244

Technical Data of AL(T)1

Installation size diagram and weight

Model	B1 (mm)	B2 (mm)	B1+B2 (mm)	D1 (mm)	D2 (mm)	Net weight (kg)
AL(T)1-2	293	235	528	135	86	20/24
AL(T)1-3	293	235	528	135	86	20/24
AL(T)1-4	314	235	549	135	86	21/25
AL(T)1-5	335	235	570	135	86	21/25
AL(T)1-6	356	235	591	135	86	22/26
AL(T)1-7	377	235	612	135	86	22/26
AL(T)1-8	398	240	638	135	86	24/28
AL(T)1-9	419	240	659	135	86	24/28
AL(T)1-10	440	240	680	135	86	25/29
AL(T)1-11	461	240	701	135	86	25/29
AL(T)1-12	488	250	738	148	96	28/32
AL(T)1-13	509	250	759	148	96	28/32
AL(T)1-15	551	250	801	148	96	29/33
AL(T)1-17	593	250	843	148	96	32/36
AL(T)1-19	635	250	885	148	96	33/37
AL(T)1-21	677	250	927	148	96	33/37
AL(T)1-22	698	250	948	148	96	34/38
AL(T)1-23	729	280	1009	166	115	40/44
AL(T)1-25	771	280	1051	166	115	41/45
AL(T)1-27	813	280	1093	166	115	42/46
AL(T)1-30	876	280	1156	166	115	43/47
AL(T)1-32	918	280	1198	166	115	46/50
AL(T)1-33	939	280	1219	166	115	46/50
AL(T)1-34	960	280	1240	166	115	47/51
AL(T)1-36	1002	280	1282	166	115	48/52
AL(T)1-38	1044	280	1324	166	115	48/52
AL(T)1-40	1086	280	1366	166	115	49/53

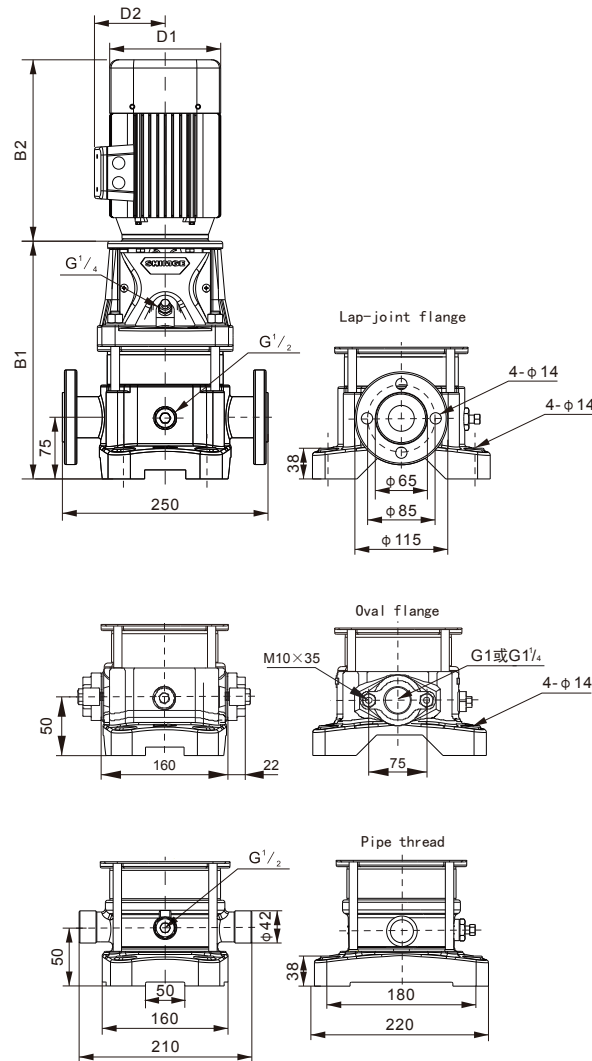

Technical Data of AL(T)3

Installation size diagram and weight

Model	B1 (mm)	B2 (mm)	B1+B2 (mm)	D1 (mm)	D2 (mm)	Net weight (kg)
AL(T)3-2	293	235	528	135	86	21/25
AL(T)3-3	293	235	528	135	86	21/25
AL(T)3-4	314	235	549	135	86	22/26
AL(T)3-5	335	240	575	135	86	23/27
AL(T)3-6	356	240	596	135	86	24/28
AL(T)3-7	383	250	633	148	96	27/31
AL(T)3-8	404	250	654	148	96	27/31
AL(T)3-9	425	250	675	148	96	29/33
AL(T)1-10	446	250	696	148	96	30/34
AL(T)3-11	467	250	717	148	96	30/34
AL(T)3-12	488	250	738	148	96	31/35
AL(T)3-13	519	280	799	166	115	36/40
AL(T)3-14	540	280	820	166	115	37/41
AL(T)3-15	561	280	841	166	115	37/41
AL(T)3-16	582	280	862	166	115	38/42
AL(T)3-18	624	280	904	166	115	40/44
AL(T)3-19	645	280	925	166	115	41/45
AL(T)3-20	666	280	946	166	115	41/45
AL(T)3-21	687	280	967	166	115	42/46
AL(T)3-22	708	280	988	166	115	42/46
AL(T)3-23	729	280	1009	166	115	43/47
AL(T)3-24	750	280	1030	166	115	43/47
AL(T)3-25	781	320	1101	191	128	54/58
AL(T)3-27	823	320	1143	191	128	55/59
AL(T)3-28	844	320	1164	191	128	55/59
AL(T)3-29	865	320	1185	191	128	55/59
AL(T)3-31	907	320	1227	191	128	56/60

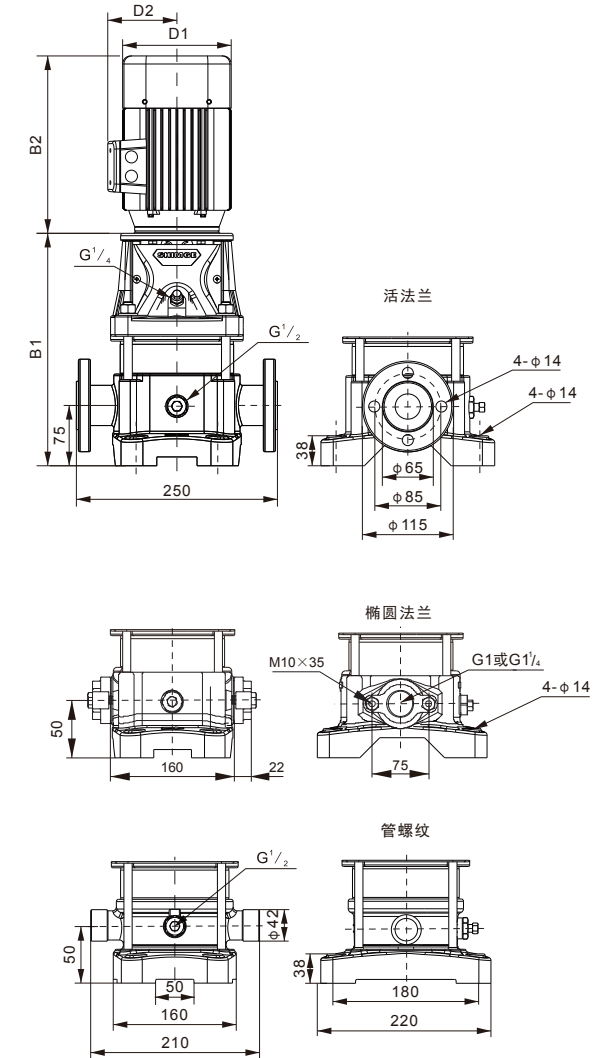

Technical Data of AL(T)5

Installation size diagram and weight

Model	B1 (mm)	B2 (mm)	B1+B2 (mm)	D1 (mm)	D2 (mm)	Net weight (kg)
AL(T)5-2	286	235	521	135	86	20/25
AL(T)5-3	314	240	554	135	86	22/27
AL(T)5-4	342	240	582	135	86	23/28
AL(T)5-5	376	250	626	148	96	26/31
AL(T)5-6	404	250	654	148	96	28/33
AL(T)5-7	432	250	682	148	96	28/3
AL(T)5-8	460	250	710	148	96	29/34
AL(T)5-9	498	280	778	166	115	34/39
AL(T)5-10	526	280	806	166	115	35/40
AL(T)5-11	554	280	834	166	115	35/40
AL(T)3-12	582	280	862	166	115	38/43
AL(T)5-13	610	280	890	166	115	38/43
AL(T)5-14	638	280	918	166	115	39/44
AL(T)5-15	666	280	946	166	115	39/44
AL(T)5-16	694	280	974	166	115	40/45
AL(T)5-18	732	320	1052	191	128	51/56
AL(T)5-19	760	320	1080	191	128	51/56
AL(T)5-20	816	320	1136	191	128	52/57
AL(T)5-21	844	320	1164	191	128	53/58
AL(T)5-22	872	345	1217	212	140	60/65
AL(T)5-23	900	345	1245	212	140	61/66
AL(T)5-24	928	345	1273	212	140	61/66
AL(T)5-27	1012	345	1357	212	140	63/68
AL(T)5-28	1040	345	1385	212	140	63/68
AL(T)5-29	1143	420	1563	258	292	83/88
AL(T)5-30	1171	420	1591	258	292	84/89
AL(T)5-33	1255	420	1675	258	292	85/90

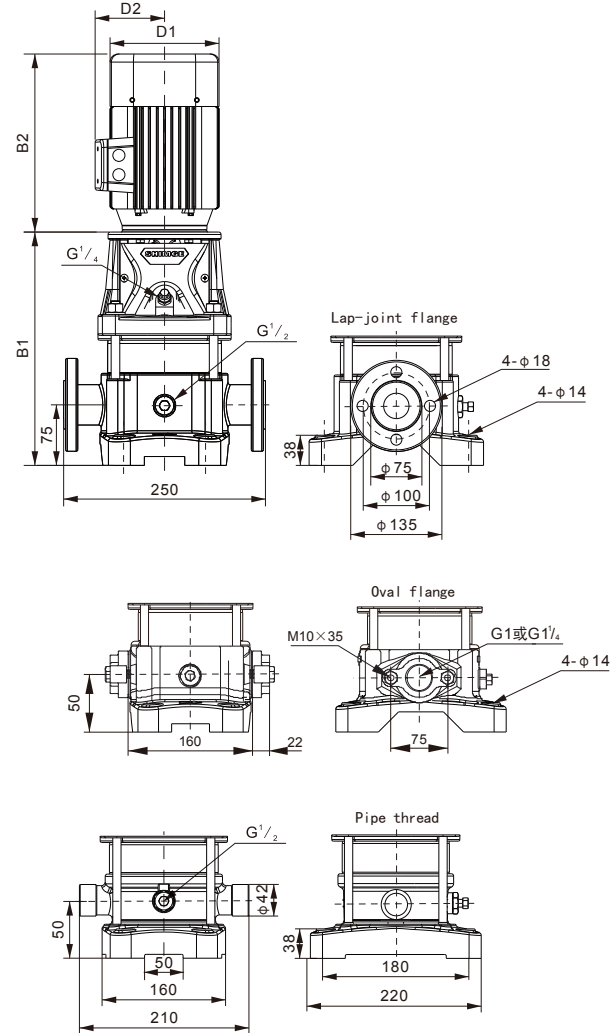

Technical Data of AL(T)10

Installation size diagram and weight

Model	B1 (mm)	B2 (mm)	B1+B2 (mm)	D1 (mm)	D2 (mm)	Net weight (kg)
AL(T)10-1	338	250	588	148	96	30/32
AL(T)10-2	338	250	588	148	96	31/33
AL(T)10-3	370	250	620	148	96	34/36
AL(T)10-4	412	280	692	166	115	40/42
AL(T)10-5	444	280	724	166	115	44/46
AL(T)10-6	476	280	756	166	115	45/47
AL(T)10-7	518	320	838	191	128	56/58
AL(T)10-8	550	320	870	191	128	57/59
AL(T)10-9	582	345	927	212	140	64/66
AL(T)10-10	614	345	959	212	140	65/67
AL(T)10-11	646	345	991	212	140	66/68
AL(T)10-13	783	420	1203	258	163	87/89
AL(T)10-14	815	420	1235	258	163	88/90
AL(T)10-15	847	420	1267	258	163	89/91
AL(T)10-16	879	420	1299	258	163	98/100
AL(T)10-17	911	420	1331	258	163	99/101
AL(T)10-18	943	420	1363	258	163	100/102
AL(T)10-19	975	420	1395	258	163	101/103
AL(T)10-20	1007	420	1427	258	163	102/104
AL(T)10-21	1039	420	1459	258	163	103/105
AL(T)10-22	1101	498	1599	315	251	169/171

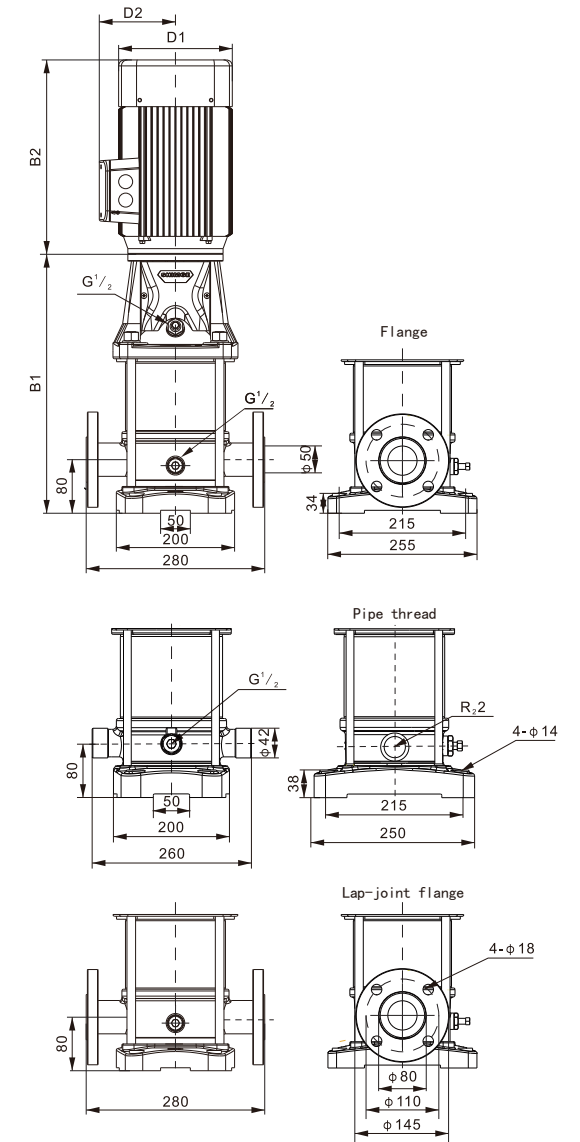

Technical Data of AL(T)15

Installation size diagram and weight

Model	B1 (mm)	B2 (mm)	B1+B2 (mm)	D1 (mm)	D2 (mm)	Net weight (kg)
AL(T)15-1	374	250	624	148	96	34/41
AL(T)15-2	384	280	664	166	115	42/49
AL(T)15-3	439	320	759	191	128	53/60
AL(T)15-4	484	345	829	212	140	60/67
AL(T)15-5	529	345	874	212	140	62/69
AL(T)15-6	647	420	1067	258	163	84/91
AL(T)15-7	692	420	1112	258	163	85/92
AL(T)15-8	737	420	1157	258	163	92/99
AL(T)15-9	782	420	1202	258	163	93/100
AL(T)15-10	857	498	1355	315	251	151/158
AL(T)15-11	902	498	1400	315	251	153/160
AL(T)15-12	947	498	1445	315	251	154/161
AL(T)15-13	992	498	1490	315	251	156/163
AL(T)15-14	1037	498	1535	315	251	157/164
AL(T)15-15	1082	498	1580	315	251	173/180
AL(T)15-16	1127	498	1625	315	251	175/182
AL(T)15-17	1172	498	1670	315	251	176/183
AL(T)15-18	1217	498	1715	315	251	178/185

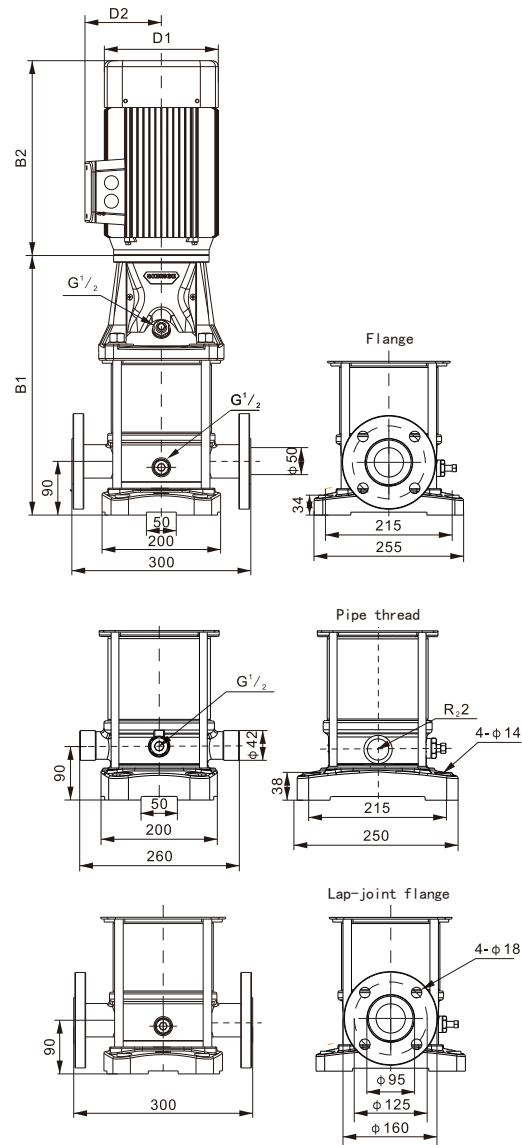

Technical Data of AL(T)20

Installation size diagram and weight

Model	B1 (mm)	B2 (mm)	B1+B2 (mm)	D1 (mm)	D2 (mm)	Net weight (kg)
AL(T)20-1	374	250	624	148	96	34/41
AL(T)20-2	384	280	664	166	115	42/49
AL(T)20-3	439	345	784	212	140	60/67
AL(T)20-4	557	420	977	258	163	82/89
AL(T)20-5	602	420	1022	258	163	84/91
AL(T)20-6	647	420	1067	258	163	93/100
AL(T)20-7	692	420	1112	258	163	94/101
AL(T)20-8	767	498	1265	315	251	161/168
AL(T)20-10	857	498	1355	315	251	164/171
AL(T)20-12	947	498	1445	315	251	182/189
AL(T)20-14	1037	498	1535	315	251	185/192
AL(T)20-17	1172	542	1714	315	251	206/213

